

Computer Science Department

**SAnToS Lab Technical Report**

Open  
Patient-Controlled Analgesia  
Infusion Pump  
System Requirements  
1.0.0

Kansas State University

This work is protected under the Creative Commons Attribution-ShareAlike license:

<http://creativecommons.org/licenses/by-sa/3.0>



## Contents

<b>1</b>	<b>Preface</b>	<b>7</b>
1.1	Context, Goals, and Emphases . . . . .	7
1.2	Licensing . . . . .	9
1.3	Providing Feedback . . . . .	9
1.4	Acknowledgements . . . . .	9
<b>2</b>	<b>Introduction</b>	<b>1</b>
2.1	Purpose . . . . .	1
2.2	Requirements from Use and Exception Cases . . . . .	1
2.3	References . . . . .	4
2.3.1	Normative References . . . . .	4
2.3.2	Informative References . . . . .	4
2.4	Terms and Acronyms . . . . .	5
<b>I</b>	<b>Environment and Use</b>	<b>7</b>
<b>3</b>	<b>System Overview</b>	<b>8</b>
3.1	Clinical Background . . . . .	8
3.2	Clinical Need . . . . .	8
3.3	System Synopsis . . . . .	9
3.3.1	Bolus Request Button . . . . .	9
3.3.2	Delivery Tube and Needle . . . . .	9
3.3.3	Physical Pump . . . . .	9
3.3.4	Drug Reservoir . . . . .	9
3.3.5	Control Panel . . . . .	9
3.3.6	Drug Library . . . . .	9
3.3.7	Scanner . . . . .	10
3.3.8	ICE Interface . . . . .	10
3.3.9	Safety Architecture . . . . .	10
3.3.10	Security . . . . .	10
3.4	System Context and External Interactions . . . . .	10
3.5	Direct PCA Pump Interactions . . . . .	11
3.6	Indirect PCA Pump Interactions . . . . .	11
3.7	System Goals . . . . .	11
<b>4</b>	<b>System Operational Concepts</b>	<b>13</b>
4.1	Use Cases . . . . .	13
4.1.1	Use Case: Normal Operation of PCA Pump (UC1) . . . . .	14
4.1.2	Use Case: Patient-Requested Bolus (UC2) . . . . .	17
4.1.3	Use Case: Clinician-Requested Bolus (UC3) . . . . .	19
4.1.4	Use Case: ICE-Detected Hazard (UC4) . . . . .	20
4.1.5	Use Case: Resume Operation After ICE-Detected Hazard (UC5) . . . . .	21
4.1.6	Use Case: Audible Alarm Inactivation (UC6) . . . . .	22
4.1.7	Use Case: Resume Infusion After Stop (UC7) . . . . .	23

- 4.1.8 Use Case: Flush (UC8) . . . . . 24
- 4.1.9 Use Case: Prime Pump (UC9) . . . . . 25
- 4.2 Exception Cases . . . . . 26
  - 4.2.1 Exception Case: Bolus Request Too Soon (EC1) . . . . . 28
  - 4.2.2 Exception Case: Drug Library Soft Limit (EC2) . . . . . 29
  - 4.2.3 Exception Case: Drug Library Hard Limit (EC3) . . . . . 30
  - 4.2.4 Exception Case: Power-On Self Test Failure (EC4) . . . . . 31
  - 4.2.5 Exception Case: Internal Electronic Failure (EC5) . . . . . 32
  - 4.2.6 Exception Case: Pump Priming Failure (EC6) . . . . . 33
  - 4.2.7 Exception Case: Over-Flow Rate Alarm (EC7) . . . . . 34
  - 4.2.8 Exception Case: Under-Flow Rate Warning (EC8) . . . . . 36
  - 4.2.9 Exception Case: Pump Overheating (EC9) . . . . . 38
  - 4.2.10 Exception Case: Downstream Occlusion (EC10) . . . . . 39
  - 4.2.11 Exception Case: Upstream Occlusion (EC11) . . . . . 40
  - 4.2.12 Exception Case: Air-in-line Embolism (EC12) . . . . . 41
  - 4.2.13 Exception Case: Maximum Safe Dose (EC13) . . . . . 42
  - 4.2.14 Exception Case: Clinician Authentication Failure (EC14) . . . . . 43
  - 4.2.15 Exception Case: Patient Authentication Failure (EC15) . . . . . 44
  - 4.2.16 Exception Case: Prescription Authentication Failure (EC16) . . . . . 45
  - 4.2.17 Exception Case: Sound Failure (EC17) . . . . . 46
  - 4.2.18 Exception Case: ICE Failure (EC18) . . . . . 47
  - 4.2.19 Exception Case: Drug Library Not Present or Corrupted (EC19) . . . . . 48
  - 4.2.20 Exception Case: Reservoir Low (EC20) . . . . . 49
  - 4.2.21 Exception Case: Reservoir Empty (EC21) . . . . . 50
  - 4.2.22 Exception Case: Diagnostic Detected Hazards (EC22) . . . . . 51
  - 4.2.23 Exception Case: Alert-Stop-Start Sequence (EC23) . . . . . 52
  - 4.2.24 Exception Case: Inactivity Timeout (EC24) . . . . . 53
  
- II Requirements . . . . . 54**
  
- 5 PCA Pump Function . . . . . 55**
- 5.1 Basal Flow Rate . . . . . 55
- 5.2 Patient-Requested Bolus . . . . . 55
- 5.3 Clinician-Requested Bolus . . . . . 56
  
- 6 PCA Pump Interfaces . . . . . 57**
- 6.1 Sensors . . . . . 57
- 6.2 Actuators . . . . . 57
- 6.3 Device Parameters . . . . . 57
- 6.4 Alarms . . . . . 57
  - 6.4.1 Alarm Priority . . . . . 58
  - 6.4.2 Alarm Visual . . . . . 60
  - 6.4.3 Alarm Audible . . . . . 60
  - 6.4.4 Alarms Networked . . . . . 61
- 6.5 Control Panel . . . . . 61

6.6	Logging . . . . .	63
6.7	ICE Interface . . . . .	63
6.8	Drug Reservoir . . . . .	64
6.9	Drug Library . . . . .	65
6.10	Scanner . . . . .	66
<b>7</b>	<b>Safety Requirements</b>	<b>67</b>
7.1	Safety Architecture . . . . .	67
7.2	Anomaly Detection and Response . . . . .	67
7.3	Power Supply . . . . .	68
7.4	Diagnostics and Fail-Stop . . . . .	68
7.5	Tamper-Resistant Door . . . . .	69
7.6	Biocompatibility . . . . .	70
7.7	Mechanical . . . . .	70
<b>8</b>	<b>Security</b>	<b>71</b>
8.1	Authentication . . . . .	71
8.2	Confidentiality . . . . .	71
8.3	Provisioning . . . . .	71
<b>III</b>	<b>Labeling and Architecture</b>	<b>72</b>
<b>9</b>	<b>Labeling of Nonfunctional Requirements</b>	<b>73</b>
<b>10</b>	<b>Functional Architecture</b>	<b>74</b>
10.1	ICE Bus Adaptor . . . . .	78
10.2	Maintenance Processor . . . . .	78
10.3	PCA Component . . . . .	79
10.4	Power Subsystem . . . . .	79
10.4.1	Power Supply . . . . .	79
10.4.2	Battery . . . . .	79
10.4.3	Power Control . . . . .	80
10.5	Operation Subsystem . . . . .	80
10.5.1	Control Panel . . . . .	80
10.5.2	Operation Process . . . . .	82
10.5.3	Boss Thread . . . . .	84
10.5.4	Rate Controller Thread . . . . .	84
10.5.5	Prescription Checker Thread . . . . .	84
10.5.6	ICE Thread . . . . .	84
10.5.7	Security Thread . . . . .	85
10.5.8	Max Drug Per Hour Thread . . . . .	85
10.5.9	Patient Bolus Checker . . . . .	85
10.5.10	Drug Library Thread . . . . .	85
10.5.11	Event Logger Thread . . . . .	86
10.5.12	Patient Button . . . . .	86
10.5.13	Scanner . . . . .	86

- 10.6 Security Subsystem . . . . . 86
- 10.7 Fluid Subsystem . . . . . 88
  - 10.7.1 Pump . . . . . 88
  - 10.7.2 Upstream Monitor . . . . . 88
  - 10.7.3 Downstream Monitor . . . . . 88
  - 10.7.4 Drug Reservoir . . . . . 90
- 10.8 Safety Subsystem . . . . . 90
  - 10.8.1 Failure LED . . . . . 90
  - 10.8.2 Alarm Thread . . . . . 92
  - 10.8.3 Flow Rate Checker . . . . . 92
  - 10.8.4 Error Detector . . . . . 92
  - 10.8.5 Fault Logger . . . . . 93

**List of Figures**

- 1 Independent PCA Pump Use . . . . . 2
- 2 ICE Framework PCA Pump Use . . . . . 3
- 3 Use Case 1, Normal Operation . . . . . 14
- 5 Use Case 1 Steps 2 to 14 . . . . . 15
- 4 Use Case 1, Normal Operation, Steps 17 to 19 . . . . . 16
- 6 Use Case 2, Step 1 Patient Button . . . . . 17
- 7 Use Case 2, Steps 2 to 4 Patient Bolus . . . . . 17
- 8 Use Case 3, Clinician-Requested Bolus . . . . . 19
- 9 Use Cases 4 and 5, ICE-Detected Hazard . . . . . 20
- 10 Use Case 6, Audible Alarm Inactivation . . . . . 22
- 11 Use Case 8: Flush Pump . . . . . 24
- 12 Use Case 9: Prime Pump . . . . . 25
- 13 Exception Case 1, Bolus Request Too Soon . . . . . 28
- 14 Exception Case 2, Drug Library Soft Limit . . . . . 29
- 15 Exception Case 3, Drug Library Hard Limit . . . . . 30
- 16 Exception Case 6, Priming Failure . . . . . 33
- 17 Exception Case 7, Over-Flow Rate Alarm . . . . . 34
- 18 Exception Case 8, Under-Flow Rate Warning . . . . . 36
- 19 Exception Case 9, Pump Overheating . . . . . 38
- 20 Exception Case 10, Downstream Occlusion . . . . . 39
- 21 Exception Case 11, Upstream Occlusion . . . . . 40
- 22 Exception Case 12, Air-in-line Embolism . . . . . 41
- 23 PCA Pump Context . . . . . 74
- 24 PCA Pump Functional Architecture Top-Level . . . . . 75
- 25 PCA Functional Components . . . . . 76
- 26 PCA Functional Components . . . . . 77
- 27 Power Subsystem . . . . . 79
- 28 Operation Subsystem . . . . . 81
- 29 Operation Processs . . . . . 83
- 30 Security Subsystem . . . . . 87

31	Fluid Subsystem . . . . .	89
32	Safety Subsystem . . . . .	91

**List of Tables**

1	Summary of PCA Use Cases . . . . .	13
2	Summary of PCA Exception Cases . . . . .	27
3	Alarm Condition Priorities . . . . .	59
4	PCA Pump Alarm Priority and Alarm Pump Rate . . . . .	59
5	Alarm Indicator Appearance . . . . .	60
6	Data Elements of a Drug Library Entry . . . . .	66
7	Top-Level Components . . . . .	78
8	Functional Components . . . . .	78
9	Operation Components . . . . .	80
10	Safety Components . . . . .	90

# 1 Preface

This document presents requirements for a mock Patient Control Analgesia (PCA) Pump. These requirements simulate the result of domain experts working with systems engineers to define function that will be safe for patients, and effective for some medical need. For PCA, the medical need is to provide narcotics to dull excruciating pain. Delivering medication as prescribed is what makes a PCA pump effective. Avoiding overdose, and all other harms to patients, is what makes a PCA pump safe.

These simulated requirements are provided as a public-domain example to facilitate research and standards development for people that do not have domain knowledge related to PCA or that need a non-propriety context in which to carry out their work. Real requirements documents are highly-confidential to medical device manufacturers, and thus detailed domain knowledge is exceedingly difficult to come by. However, since showing safety and effectiveness can be legal necessities for regulatory approval, and since university curricula and other training for engineers needs to address relevant topics in settings that are as realistic as possible, these simulated requirements were created to fill the vacuum.

## 1.1 Context, Goals, and Emphases

The first draft of this document was written by Brian R Larson, Research Associate, as part of an academic research project in the SAnToS research group at Kansas State University (KSU) funded by funded by the National Science Foundation US Food and Drug Administration Scholar-in-Residence (NSF FDA SIR) program. Thus, the emphases and content of the document are driven by broader mission goals of the NSF FDA SIR program and KSU SAnToS – specifically, the goal of providing resources primarily to the academic community (but also to industry and government agencies) that will facilitate research in safety critical systems, requirements engineering, hazard analysis and risk management, rigorous model-based development, formal specification and verification, and interoperable medical systems. Academic research groups and class instructors often do not have the resources to provide domain knowledge and artifacts that illustrate realistic challenges in medical system development.

This ongoing project attempts to gather relevant domain knowledge and supporting artifacts that will provide a more realistic context for research and pedagogical projects. Many persons have or will contribute including students, faculty, researchers and perhaps, *you*.

The primary goals of this document are as follows:

- *Illustrate best practices in systems engineering and requirements management.* This document follows the methodology and content suggestions presented in the Federal Aviation Administration (FAA) Requirements Engineering Management Handbook (REMH) (DOT/FAA/AR-08/32). We have found the FAA REMH to be especially well-aligned with our goals because, in contrast to other well-known requirements guidelines such as IEEE Std 830-1998, the FAA REMH brings a systems engineering perspective and emphasizes aspects relevant to embedded safety-critical systems.
- *Provide a pathway to formal architecture definitions and other associated formal development*

*artifacts.* Although some argue that any notion of architectural specification falls in the domain of design rather than requirements, the FAA REMH emphasizes the initial high-level specification of a system architecture to enable allocation of requirements to subsystems as part of the requirements engineering process. This document amplifies that view by including formal architecture descriptions written in the SAE standard Architecture and Analysis Definition Language (AADL). This sets the stage for other activities that support our broader goals of illustrating formal/rigorous development artifacts – in particular, detailed architectural specifications in AADL with traceability links to requirements, formal annotations in the AADL Error Modeling Annex that support partial automation of hazard analyses and other risk management activities, formal interface and component behavioral specifications in the Behavioral Language for Embedded Software and Systems (BLESS).

- *Enable demonstrations of formal verification of system behavior and system assurance activities.* The mission of the KSU SAnToS research group and the focus of our NSF FDA SIR activities includes developing formal methods tools that can be applied to realistic systems. We aim to facilitate the same type of research within other groups in the academic community. Thus, this document focuses on requirements that will drive verification of behavioral properties. While other classes of requirements for useability, physical housing, electrical and other hardware aspects are important in real-world products, they are not as well-developed in this document due to our limited domain knowledge, resources, and the need to focus on requirements associated with functional and real-time behavior, risk management, and interoperability.
- *Providing concrete examples of interoperability interfaces.* KSU SAnToS has a significant research emphasis on Medical Application Platforms (MAPs). A MAP is a safety- and security-critical real-time computing platform for (a) integrating heterogeneous devices, medical IT systems, and information displays via a communication infrastructure and (b) hosting application programs (i.e., *apps*) that provide medical utility via the ability to both acquire information from and update/control integrated devices, IT systems, and displays. Through the NSF Cyber-Physical Systems program, KSU and University of Pennsylvania are jointly developing a prototype MAP called the Medical Device Coordination Framework (MDCF). The MDCF aims to illustrate best engineering principles for interoperability frameworks conforming to the Interoperable Clinical Environment (ICE) architecture specified in the ASTM F2761 standard. One of the primary use cases being considered in ICE-related work is a MAP app for PCA monitoring that implements a safety interlock by halting pump infusion when monitoring devices such as pulse oximeters and capnography indicate a potential analgesic overdose. The PCA safety interlock app uses a MAP to integrate the monitoring devices as well as a PCA pump and relies on the fact that a variety of data and control including physiological parameters, alarms, device settings and configuring, and pump control aspects are exposed on network interfaces. No PCA pump on the market today includes capabilities on a non-proprietary network interface that are sufficient for supporting this application. Moreover, developing appropriate specifications for interface functionality and safety is still a topic of active research within the ICE community and in AAMI and UL standards committees. This document aims to provide a realistic, non-proprietary, open-source context for exploring PCA pump ICE network interface functionality and safety that would be appropriate for supporting the PCA safety interlock app described above. The details of an ICE interface have not yet been fully developed within the current version of this document – only preliminary



information is given. However, we intend to include a proposal for a complete PCA Pump ICE interface in subsequent versions.

This document is part of a broader set of artifacts meant to illustrate best practices in engineering safety-critical medical devices. Other open source artifacts being developed by KSU SAnToS for the PCA pump include detailed hardware/software architectural descriptions specified in AADL, use cases and requirements modeling with automated traceability to the AADL architecture, formal behavioral specifications in BLESS, and an assurance case for the PCA pump.

Lecture materials with slides and lecture videos for the FAA REMH, hazard analyses and risk management, AADL, and BLESS are also available from the research group.

## 1.2 Licensing

This work is protected under the Creative Commons Attribution-ShareAlike license. This license lets others remix, tweak, and build upon this work even for commercial purposes, as long as they credit this document and its authors, and license their new creations under the identical terms.

## 1.3 Providing Feedback

The authors welcome feedback and suggestions for improving this document. To provide feedback send email to `hatcliff 'at' ksu.edu`.

## 1.4 Acknowledgements

This document builds off of the Generic Infusion Pump (GIP) and Generic PCA (GPCA) Pump work jointly developed by the University of Pennsylvania (U Penn) and FDA engineers Paul Jones and Raoul Jetly. Dave Arney, previously from U Penn and now from the CIMIT Medical Device Plug-and-Play (MDPnP) interoperability group, played a significant role in the GIP and GPCA efforts and provided several important forms of source material for this requirements document. FDA engineers Paul Jones and Sandy Weininger who shepherd the NSF FDA Scholars-in-Residence provided valuable feedback on earlier drafts of this document. Dr. Julian Goldman, head of the CIMIT MDPnP program also provided feedback, resources, and encouragement.

Funds for KSU SAnToS's broader work on medical device interoperability were provided by the National Science Foundation under grants #0932289,1065887,1238431,1239543 and by a subcontract from the CIMIT MDPnP group funded via an NIH/NIBIB Quantum grant.

## Disclaimer

No physicians have reviewed these simulated requirements for a generic system to determine that they are actually safe and effective for real patients. DO NOT USE THESE REQUIREMENTS

TO BUILD DEVICES USED ON PEOPLE. No warranty, expressed or implied, is made for these requirements by anyone.

## 2 Introduction

This document defines requirements for patient-controlled analgesia (PCA) infusion pumps for use in an Integrated Clinical Environment (ICE). In particular, this device may communicate with, and be controlled by an ICE application or “app.”

As much as possible, these requirements define what an ICE PCA infusion pump must do, and how it interacts with ICE apps. Implementations may have other features not mentioned in these requirements; they are a minimum for ICE-compliance. As much as possible design and implementation of an ICE-compliant PCA infusion pump are left unspecified.

These requirements are based upon the Generic Patient-Controlled Analgesia (GPCA) infusion pump work done at the University of Pennsylvania, sponsored by the U.S. Food and Drug Administration, and FDA’s guidance document on infusion pumps.<sup>1</sup>

### 2.1 Purpose

A patient-controlled analgesia (PCA) infusion pump infuses narcotic, liquid pain-killer at a prescribed basal rate plus any bolus doses that the patient may request to alleviate their pain, or be commanded by an attending clinician, most often, a registered clinician (Figure 1).<sup>2</sup> Pain medication is prescribed by a licensed physician, which is dispensed by the hospital’s pharmacy. The drug is placed into a vial labeled with the name of the drug, its concentration, the prescription, and the intended patient. A clinician loads the drug into the pump, and attaches it to the patient. The pump infuses a prescribed basal flow rate which may be augmented by a patient-requested bolus or a clinician-requested bolus. This allows additional pain medication in response to patient need within safe limits.

An ICE PCA pump provides a standard ICE interface so it may be integrated with ICE apps and displays (Figure 2). The interface must provide prescription and patient information, current status to be displayed remotely on a supervisor user interface, and a means to stop infusing upon human command, or determination of an ICE app. Such an ICE app could monitor a patient’s blood oxygenation and pulse rate, stopping the pump if depressed respiratory function is indicated.

### 2.2 Requirements from Use and Exception Cases

The sections starting with §5 define the requirements—one per paragraph. Where applicable, the use or exception case(s) the requirement derives from, are listed and hyperlinked.

Each requirement is assigned a unique identifier, beginning with ‘R’, corresponding to their location in the document. In addition, the requirement identifier and title are listed in a footnote, and included in the index.

---

<sup>1</sup>PCA pumps are FDA product code “MEA.”

<sup>2</sup>Essentially, FDA’s GPCA pump without an ICE interface.

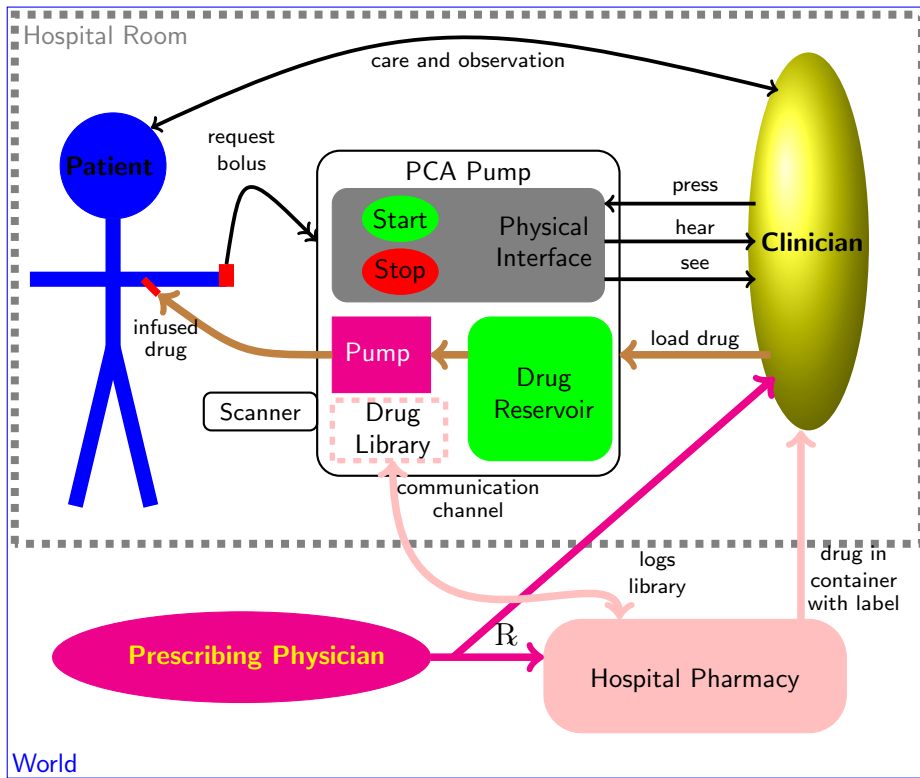

Figure 1: Independent PCA Pump Use

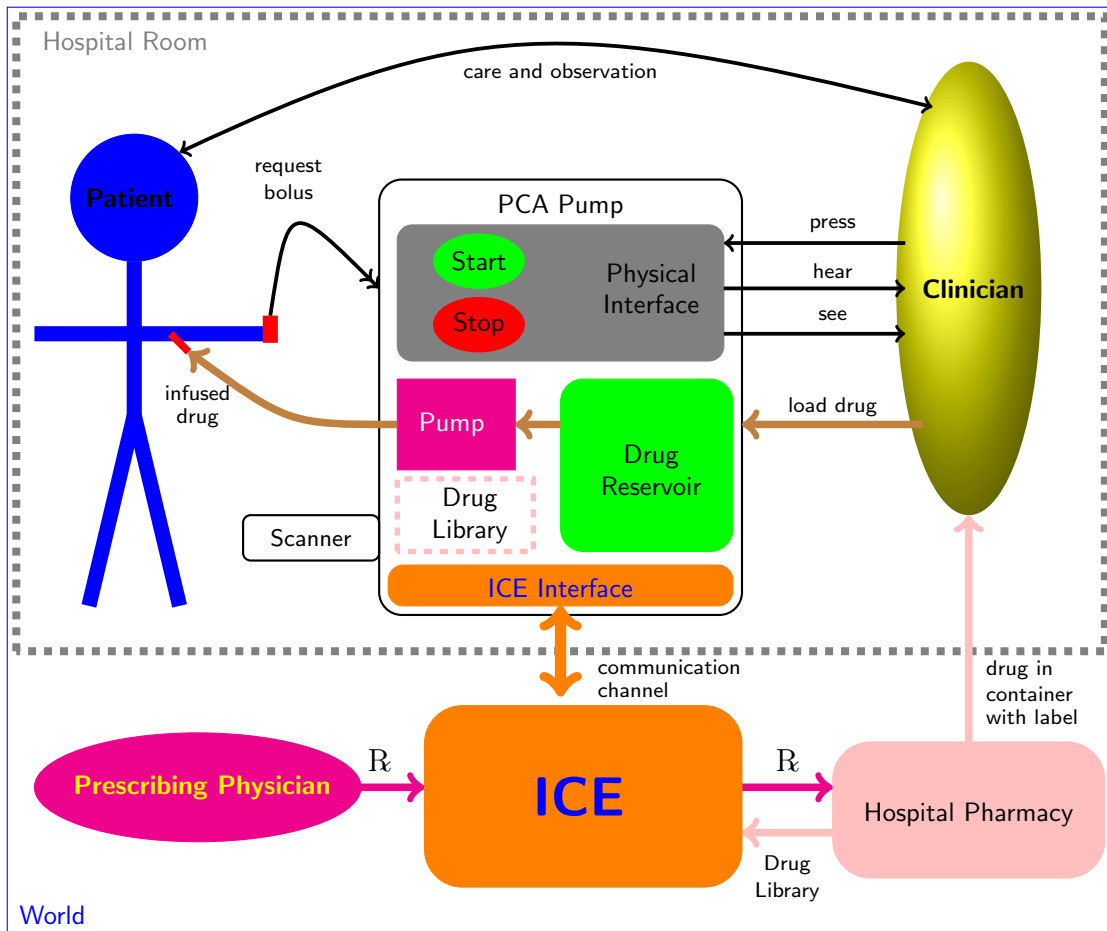

Figure 2: ICE Framework PCA Pump Use

Each requirement is then allocated to a component<sup>3</sup> in the functional architecture, starting section §10. Each requirement entry in the index is thus linked to both the statement of the requirement, and the functional architecture component to which it was allocated.

## 2.3 References

Normative references are mandatory; informative references provide background.

### 2.3.1 Normative References

The following referenced documents are indispensable for the application of this document.

ASTM International F2761-09 *Medical Devices and Medical Systems—Essential safety requirements for equipment comprising the patient-centric integrated clinical environment (ICE)—Part 1 General requirements and conceptual model*

IEC 60601-1-8 *Medical electrical equipment Part 1-8: General requirements for basic safety and essential performance Collateral Standard: General requirements, tests and guidance for alarm systems in medical electrical equipment and medical electrical systems*

IEC 60601-1 (1988) *Medical electrical equipment Part 1: General requirements for safety, including Amendment 1 (1991) and Amendment 2 (1995) for Type B equipment*

IEC 60601-1 *Collateral Standard: Safety requirements for medical electrical systems*

IEC 60601-1-2 (2001) *Medical Electrical Equipment, Part 1: General Requirements for Safety, 2. Collateral Standard: Electromagnetic Compatibility - Requirements and Tests*

SAE International AS5506B *Architecture Analysis & Design Language (AADL)*

IEC 60601-2-24 *Particular Requirements for safety of infusion pumps and controllers*

### 2.3.2 Informative References

The following references provided a starting point from which these requirements were embellished and extended.

“Safety Requirements for the Generic Patient Controlled Analgesia Pump”<sup>4</sup>

“The Generic Patient Controlled Analgesia Pump Model,” Oleg Sokolsky, University of Pennsylvania.<sup>5</sup>

“gpca\_spec\_dlg.aadl,” Oleg Sokolsky, University of Pennsylvania

<sup>3</sup>Some requirements require the cooperation of two or more functional components.

<sup>4</sup>Author unspecified, believed to be a collaboration between the FDA and the University of Pennsylvania.

<sup>5</sup>Similarities between these requirements and the GPCA pump developed at the University of Pennsylvania are deliberate. GPCA documents can be found at <http://rtg.cis.upenn.edu/gpca-aadl/wiki/>.

“Total Product Life Cycle: Infusion Pump - Premarket Notification [510(k)] Submissions,” U.S. Food and Drug Administration, April 23 2010.<sup>6</sup>

## 2.4 Terms and Acronyms

**app** application, a program that coordinates physical medical devices that is regulated as a medical device itself

**ASTM** International, formerly known as the American Society for Testing and Materials

**basal** base rate of drug infusion

**bolus** single dose of a drug or other medicinal preparation given all at once

**bty** battery

**ccb** clinician-requested bolus

**C** Celsius

**CT** Computerized Tomography

**DEA** U.S. Drug Enforcement Agency

**FDA** U.S. Food and Drug Administration

**GPCA** Generic Patient-Controlled Analgesia (pump)

**Hg** mercury

**hr** hour

**ICE** Integrated Clinical Environment

**IEC** International Electrotechnical Commission

**ISO** International Organization for Standardization

**KVO** keep vein open

**lba** low battery alarm

**LED** light-emitting diode

**lra** low reservoir alarm

**max** maximum

**min** minimum

**ml** milliliter

**NSF** U.S. National Science Foundation

**PCA** Patient-Controlled Analgesia (pump)

---

<sup>6</sup><http://www.fda.gov/MedicalDevices/DeviceRegulationandGuidance/GuidanceDocuments/ucm206153.htm>

**POST** power-on self test

**psi** pounds per square inch

**RF** radio frequency

**RFID** radio frequency identification

**SAE** International, formerly known as the Society of Automotive Engineers

**TPM** Trusted Platform Module

**VTBI** volume to be infused



## **Part I**

# **Environment and Use**

## 3 System Overview

Patient-controlled analgesia (PCA) is a means for the patient to self-administer analgesics (pain medications) intravenously by using a computerized pump, which introduces specific doses into an intravenous line.

### 3.1 Clinical Background

The purpose of PCA is improved pain control. The patient receives immediate delivery of pain medication without the need for a clinician to administer it. The patient controls when the medication is given. More importantly, PCA uses more frequent but smaller doses of medication, and thus provides more even levels of medication within the patient's body. Syringe-injected pain management by a clinician requires larger doses of medication given less frequently. Larger doses peak shortly after administration, often causing undesirable side effects such as nausea and difficulty in breathing. Their pain-suppressing effects also often wear off before the next dose is scheduled.

### 3.2 Clinical Need

PCA uses a computerized pump, which is controlled by the patient through a hand-held button that is connected to the machine. The pump usually delivers medications in small regular doses, and it can be programmed to issue a large initial dose and then a steady, even flow. The PCA pump can deliver medicine into a vein (intravenously, the most common method), under the skin (subcutaneously), or between the dura mater and the skull (epidurally).

When the patient feels the need for medication, the patient presses a button similar to a clinician call button. When this button is pressed, some sound (usually a beep) is heard, indicating that the pump is working properly and that the button was pressed correctly. The pump delivers the medication through an intravenous line, a plastic tube connected to a needle inserted into a vein. Glucose and other medications can also be administered through intravenous lines, along with analgesics.

The medications most commonly used in PCA pumps are synthetic, opium-like pain-relievers (opioids), usually morphine and meperidine (Demerol).

The pump may be set to deliver a larger patient-requested dose of the prescribed drug. The health-care provider sets the pump to deliver a specified dose (a.k.a. bolus), determined by the prescribing physician, on demand, subject to a minimum time between deliveries. For example, 1 mg of medicine on demand, but not more frequently than one patient-requested dose every six minutes. If the patient presses the button before six minutes have elapsed, the pump will not dispense the medication. The pump also generates a record that the health personnel can access.

A continuous, even dose (a.k.a. basal rate) may also be set. The practitioner sets a total limit of medicine for an hour (or any other period) that takes into account the initial dose, the demand doses, and the around-the-clock doses. The pump's internal computer calculates all these amounts, makes a record of the requests it received and those it refused, and also keeps inventory of the medication being administered, which warns the staff when the supply is getting low.

### 3.3 System Synopsis

A patient-controlled analgesia (PCA) pump infuses pain killing medication into patients allowing patients to regulate (within bounds) the amount of medication they receive, and is depicted in Figure 1. An ICE PCA pump augments the function of a stand-alone PCA pump with communication and control by the ICE system which allows clinician's to remotely monitor the operation of the pump, and ICE apps to coordinate its operation with other ICE devices, and is depicted in Figure 2.

#### 3.3.1 Bolus Request Button

Patients press a button to request a drug bolus in addition to a constant basal rate. The bolus request button is connected by a cable to the PCA pump, and may have a clip to attach to patient's bedding.

#### 3.3.2 Delivery Tube and Needle

The drug is conveyed from the pump to a needle to to be infused into the patient. The needle is placed into a vein, usually in an arm or hand.

#### 3.3.3 Physical Pump

A physical pump forces the drug into the delivery tube at specified rates. It also measures pressure and flow, and detects occlusion and air-in-line embolism (bubbles).

#### 3.3.4 Drug Reservoir

A drug reservoir holds the prescribed drug in a vial for extraction by the physical pump. Because the drugs administered are narcotic and may be abused, the drug reservoir must be tamper resistant. The drug reservoir also has an electronic means, such as optical code, to read the prescription from the vial labeled by the hospital's pharmacy.

#### 3.3.5 Control Panel

A Control Panel allows the pump to be started and stopped. It allows a clinician to command delivery of a bolus. It also allows a clinician to specify the duration a prescribed volume-to-be-infused is delivered. Pump status and alarms are displayed or sounded by the physical interface.

#### 3.3.6 Drug Library

A drug library containing information about drugs that may be used by the pump is stored in non-volatile memory. The drug library is determined by the hospital pharmacy.

### 3.3.7 Scanner

A scanner allows the entry of patient, clinician, and prescription information automatically reducing both the work needed to operate the pump and possible harm to the patient through manual entry errors. The scanner may be optical or radio-frequency identification (RFID).

### 3.3.8 ICE Interface

An ICE interface uses a communication channel to connect to the ICE system.

### 3.3.9 Safety Architecture

The system uses a safety architecture that separates normal operation from error and anomaly detection and response.

### 3.3.10 Security

Authentication of prescriptions, patients, and clinicians reduces risk of malicious or accidental harm.

## 3.4 System Context and External Interactions

The *environment* of the PCA pump is the patient, the clinician, the prescribing physician, the hospital room, and the hospital pharmacy.

By intent, the *patient* is part of the control loop determining the amount/rate of narcotic pain-killer infused into their blood through a tube leading to a needle in a patient's vein. Safety and efficacy properties of PCA relate to the patient.

The *clinician* connects the PCA pump to the patient, loads the liquid pain-killer received from the hospital pharmacy, and enters a physician's prescription for the particular patient connected to the pump.

The PCA pump will operate in a *hospital room* or similar clinical setting: controlled ambient temperature, assured power,<sup>7</sup> lighting, infection-control procedures and equipment, normal electromagnetic fields and particles,<sup>8</sup>

The *hospital pharmacy* dispenses the drug loaded into the PCA pump according to the physician's prescription. The hospital pharmacy also determines the drug library programed into the pump, regularly updated from the pharmacy's central repository.

The PCA pump may communicate with, and be controlled by, an ICE app.

---

<sup>7</sup>source of power is an implementation choice, defaulting to 60 Hz 120V

<sup>8</sup>No MRI magnetic fields, CT scanner X-ray, radiation therapy, RF transmitters, etc.; just 50 or 60 cycle hum and unavoidable cosmic ray-induced neutrons and pions.

- (1) The PCA pump should be able to operate within a *temperature range*<sup>9</sup> of  $T_{lo} = 10\text{C}$  to  $T_{hi} = 50\text{C}$ .<sup>10</sup>
- (2) The pump should be able to withstand and operate under *atmospheric pressure*<sup>11</sup> ranging from  $P_{min} = 20''\text{Hg}$  to  $P_{max} = 35''\text{Hg}$ .
- (3) The (external) pump should be able to operate at *relative humidity*<sup>12</sup> ranging from  $H_{min} = 0\%$  to  $H_{max} = 100\%$  (non-condensing).
- (4) The PCA pump shall withstand *splashing*<sup>13</sup> (but not immersion) with water or bodily fluids.

### 3.5 Direct PCA Pump Interactions

An ICE PCA pump interacts directly with the patient through the bolus request button and the delivery tube/needle. It interacts directly with an attending clinician who connects it to the patient, sets bolus delivery duration, commands bolus delivery, and responds to alarms.

### 3.6 Indirect PCA Pump Interactions

An ICE PCA pump interacts indirectly with the ICE system which may include a supervisor user interface to monitor and control the pump, or app(s) that may stop infusion if abnormal conditions are detected by other devices such as slow heart rate or low blood oxygenation.

### 3.7 System Goals

The high-level goals (G) of the PCA pump are:

- G0** The pump will safely infuse drugs intravenously for pain relief.
- G1** The patient should receive enough drug to reduce his pain.
- G2** The patient should not receive so much drug that makes him unaware, or is harmful.
- G3** Clinician(s) should be notified upon occurrence of hazardous conditions, unless alarms have been inactivated.
- G4** The PCA pump should detect the smallest-possible air-in-line embolism (bubble) and halt the infusion drug.
- G5** The PCA pump should infuse safely when failures occur or hazards are detected<sup>14</sup>

<sup>9</sup>requirement R3.4.0(1): *temperature range*

<sup>10</sup>These environmental requirements pertain to the use of the PCA pump, not its design or function.

<sup>11</sup>requirement R3.4.0(2): *atmospheric pressure*

<sup>12</sup>requirement R3.4.0(3): *relative humidity*

<sup>13</sup>requirement R3.4.0(4): *splashing*

<sup>14</sup>Some failures/hazards halt pumping; others switch to keep-vein-open (KVO) rate; or continue current basal or bolus rate

**G6** Patients should receive the drug as prescribed by their physician, administered by appropriate clinicians.

**G7** Patient's health information should be available to those caring for the patient, and only those.

## 4 System Operational Concepts

The PCA pump infuses a prescribed basal flow rate augmented with a bolus dose upon patient or clinician request. When infusion is suspended, the pump shall maintain a minimal keep-vein-open (KVO) rate of infusion. The pump shall halt infusion upon pump failures.

### 4.1 Use Cases

The following use cases describe normal operation of the PCA pump. Exception cases are described in Section 4.2. A summary of uses cases is provided in Table 1.

Table 1: Summary of PCA Use Cases

ID	Primary Actor	Title	Description
UC1	Clinician	Normal Operation	initialization, attachment, basal infusion, detachment
UC2	Patient	Patient-Requested Bolus	extra dose upon patient-determined need
UC3	Clinician	Clinician-Requested Bolus	extra dose upon clinician-determined need
UC4	ICE app	ICE-Detected Hazard	switch to KVO infusion rate upon ICE app-determined need
UC5	Clinician	Resume Operation After ICE-Detected Hazard	resume prescribed infusion after clinician determines it is safe
UC6	Clinician or App	ICE-Initiated Audible Alarm Inactivation	suspend audible alarm from ICE
UC7	Clinician	Resume Infusion	continue infusion after Stop
UC8	Clinician	Flush Pump	cleanse pump after use
UC9	Clinician	Prime Pump	expel air from tube and needle

Use case maps *use case map* graphically depict use and exception cases as a flow of actions. Use cases begin at a filled circle and end at a perpendicular bars. An X represents an action or responsibility. A diamond represents a stub to a subordinate use case. A colored box represents some entity in the use case. Location of an X designates the entity that performs an action. A *scenario* is a particular sequence of actions. In each of the use case maps, the sequence of actions corresponding the use or exception case are colored blue.<sup>15</sup>

<sup>15</sup>These use case maps are part of an architectural model of a device that implements the requirements in this document. This model is defined in the Architecture Analysis and Design Language (AADL) using the Open-Source AADL Tool Environment (OSATE). OSATE is a plug-in to Eclipse which itself supports plugins. The plug-in used to create the use case maps is jUCMNav.

#### 4.1.1 Use Case: Normal Operation of PCA Pump (UC1)

This use case describes normal operation of the PCA Pump. Steps 1 through 14 define the actions required to begin infusing. Steps 17 through 19 define the steps actions to cease infusing. Step 15 is infusion, defined in other use cases, terminated by step 16, pressing the stop button.

**Related System Goals** G1 and G2

**Primary Actor** Clinician

**Precondition**

- Patient is ready for infusion
- Physician has prescribed drug
- Pharmacy has filled prescription
- Pharmacy has installed drug library into PCA pump
- Drug has been delivered to clinician
- PCA pump is off

**Postcondition**

- PCA pump is turned off
- Infusion needle removed from patient

**Main Success Scenario**

1. Clinician turns on PCA pump (Exception Case: Power-On Self Test Failure)
2. Clinician presses button when hearing audible alarm sound (Exception Case: Sound Failure)
3. Clinician scans own badge
4. Clinician is authenticated to operate PCA pump (Exception Case: Clinician Authentication Failure)
5. Clinician scans patient information (wristband)
6. Patient is authenticated to receive medical care (Exception Case: Patient Authentication Failure)

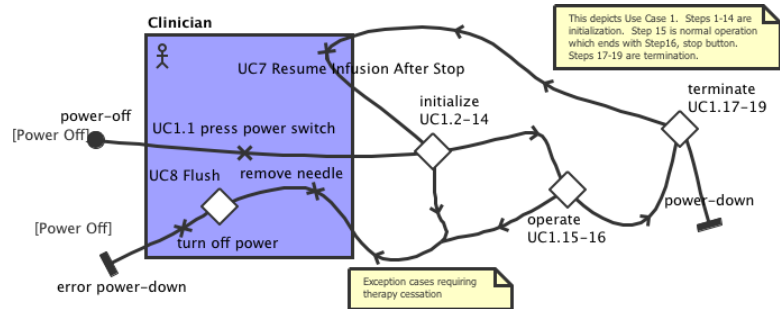

Figure 3: Use Case 1, Normal Operation



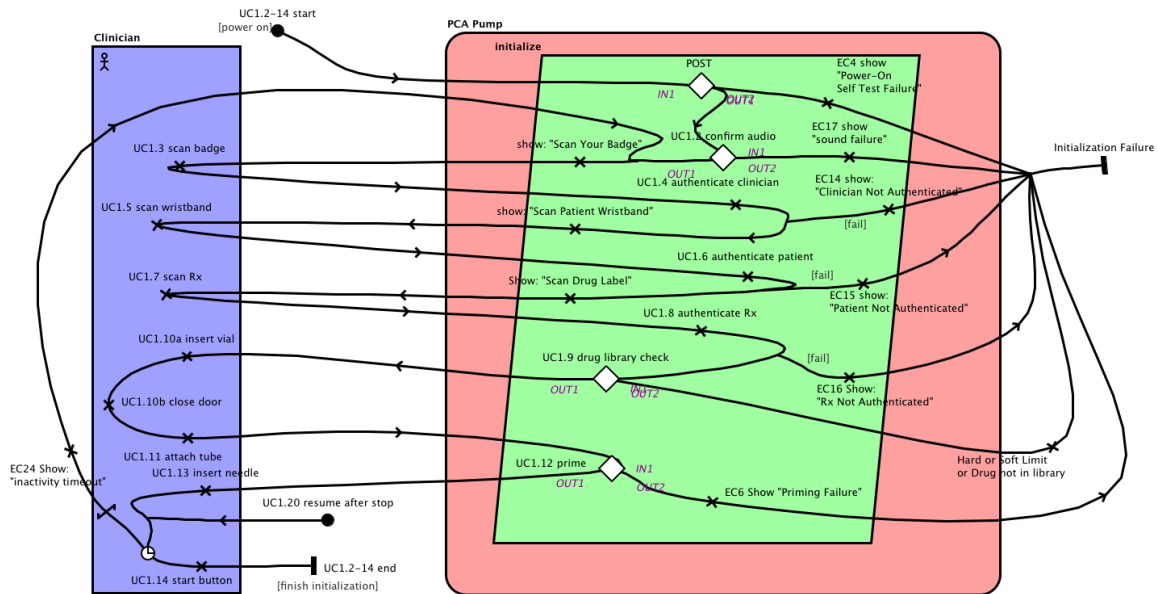

Figure 5: Use Case 1 Steps 2 to 14

7. Clinician scans drug information and patient's prescription from drug container (vial)
8. Prescription is authenticated for the patient (Exception Case: Prescription Authentication Failure)
9. PCA pump compares prescription with its drug library (Exception Cases: Drug Library Soft Limit and Drug Library Hard Limit)
10. Clinician puts drug vial into the reservoir and closes and locks the door
11. Clinician attaches infusion tube and needle to pump
12. Clinician primes pump (Exception Case: Pump Priming Failure)
13. Clinician inserts infusion needle into patient's vein
14. Clinician presses Start button to begin basal-rate infusion
15. Bolus dose infused upon request; see Use Case: Bolus Infusion
16. Clinician presses Stop button to halt infusion
17. Clinician removes infusion needle from patient's vein, and infusion tube from pump
18. Clinician removes drug vial, returning remaining drug to pharmacy
19. Clinician turns off PCA pump power.

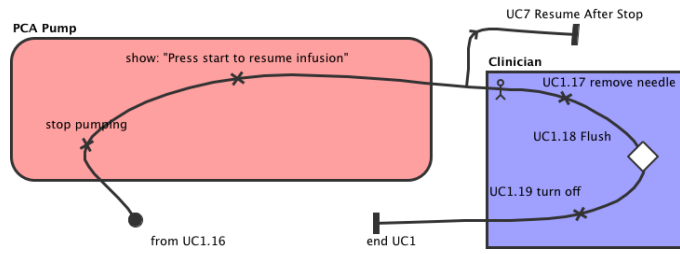

Figure 4: Use Case 1, Normal Operation, Steps 17 to 19

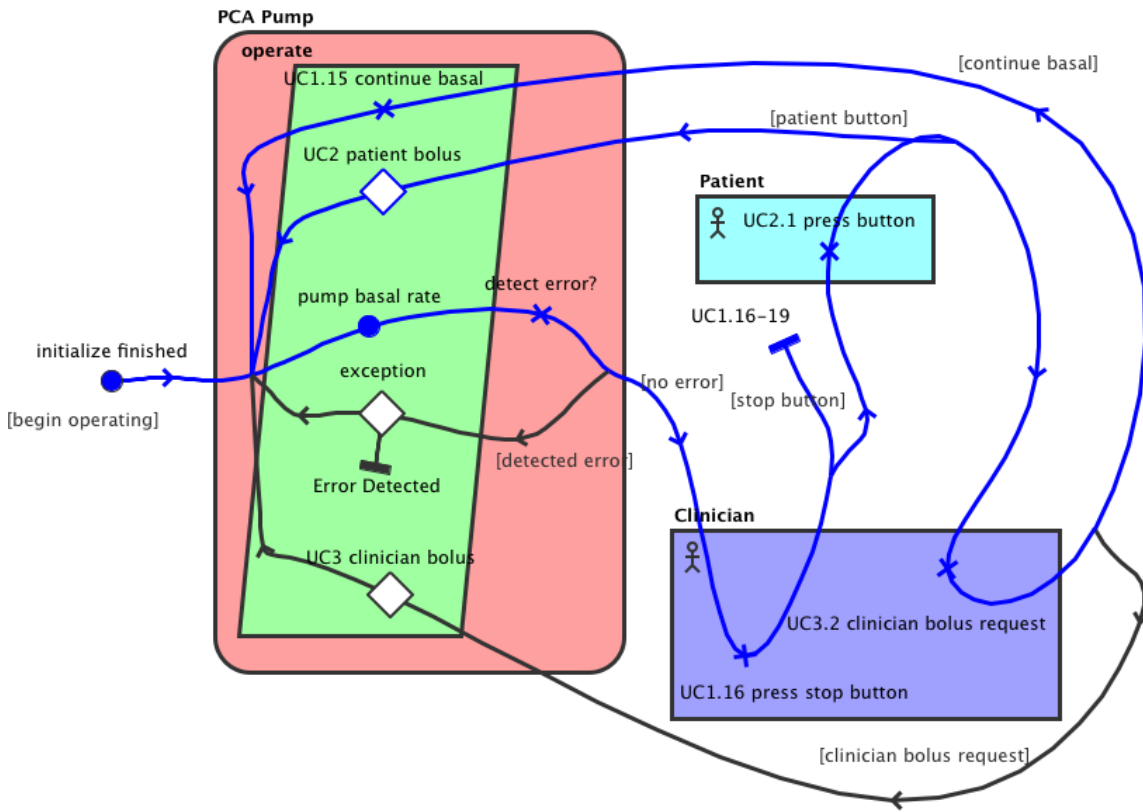

Figure 6: Use Case 2, Step 1 Patient Button

#### 4.1.2 Use Case: Patient-Requested Bolus (UC2)

This use case describes operation when the patient requests an extra dose of drug.

**Related System Goals** G1 and G2

**Primary Actor** Patient

**Precondition**

- Steps 1 to 14 of Normal Operation Use Case completed
- Basal rate being infused
- Prescribed minimum time between boluses has elapsed

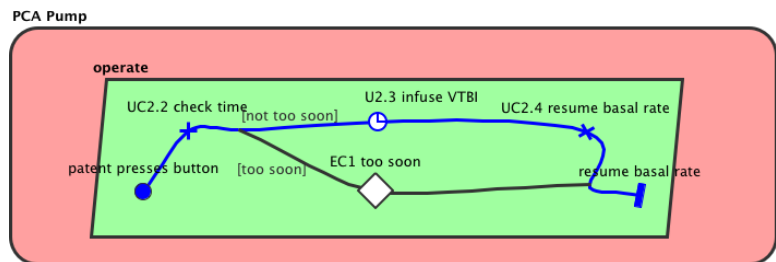

Figure 7: Use Case 2, Steps 2 to 4 Patient Bolus

**Postcondition**

- Resume basal rate infusion

**Main Success Scenario**

1. Patient presses bolus request button
2. Time since last bolus compared with prescribed minimum time between boluses (Exception Case: Bolus Request Too Soon)
3. If not too soon, begin infusing VTBI (Exception Case: Maximum Safe Dose)
4. After prescribed volume-to-be-infused (VTBI) has been infused, resume basal rate infusion

### 4.1.3 Use Case: Clinician-Requested Bolus (UC3)

This use case describes operation when the clinician requests an extra dose of drug.

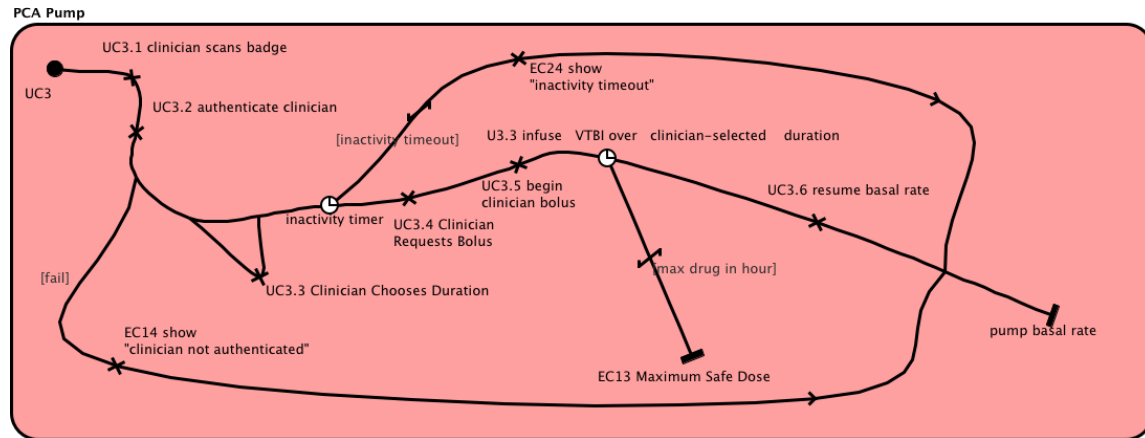

Figure 8: Use Case 3, Clinician-Requested Bolus

#### Related System Goals G1 and G2

#### Primary Actor Clinician

#### Precondition

- Steps 1 to 14 of Normal Operation Use Case completed
- Basal rate being infused

#### Postcondition

- Resume basal rate infusion

#### Main Success Scenario

1. Clinician scans own badge
2. Clinician is authenticated to operate PCA pump (Exception Case: Clinician Authentication Failure)
3. Clinician (optionally) sets duration of bolus infusion on Control Panel or ICE supervisor user interface
4. Clinician requests bolus infusion on Control Panel, by pressing the Start Button (Exception Case: Inactivity Timeout)
5. Begin infusing bolus at rate so that prescribed VTBI is infused over the duration selected by the clinician, interrupted by a patient-requested bolus, and resumed afterward. (Exception Case: Maximum Safe Dose)
6. When the duration ends, resume basal rate infusion

#### 4.1.4 Use Case: ICE-Detected Hazard (UC4)

This use case describes operation when an ICE app determines a hazard may exist by monitoring other ICE devices such as pulse oximeters, respiration monitors, or electrocardiograms.

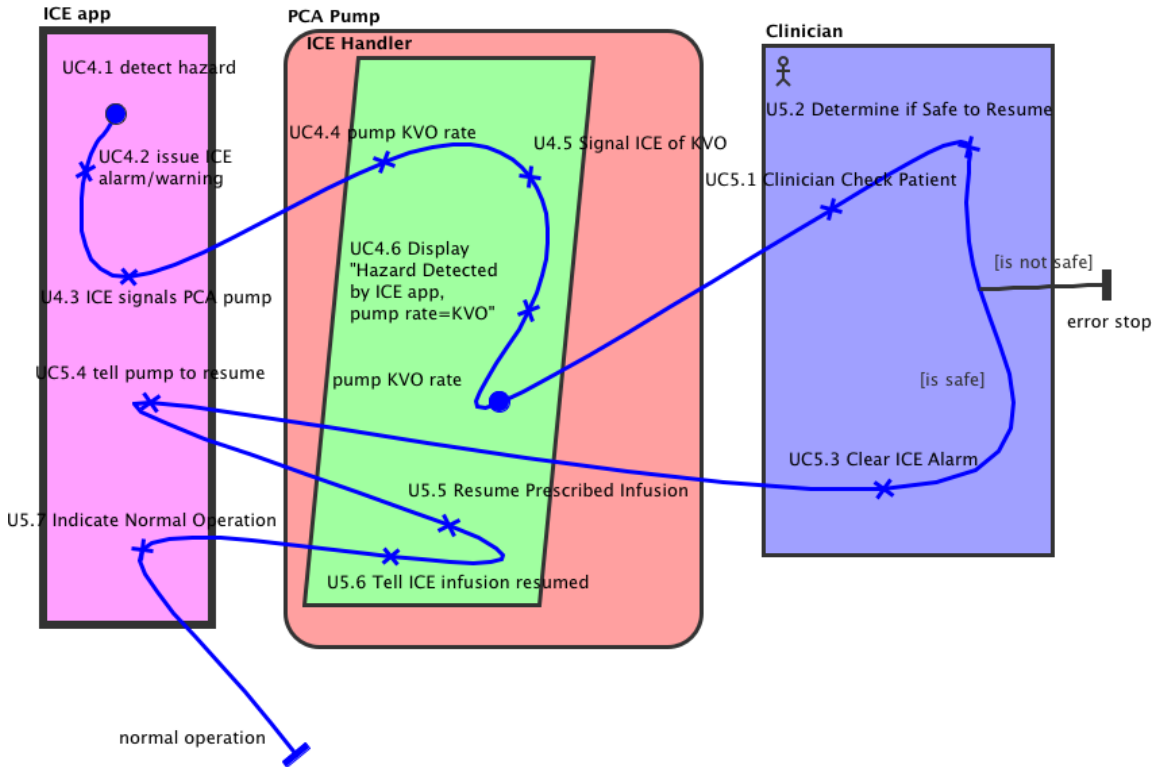

Figure 9: Use Cases 4 and 5, ICE-Detected Hazard

#### Related System Goals G2 and G3

#### Primary Actor ICE App

#### Precondition

- Steps 1 to 14 of Normal Operation Use Case completed
- Basal rate or bolus rate being infused
- PCA pump communicating with ICE system
- Monitoring device(s) communicating with ICE system
- ICE app initialized and registered to PCA pump and monitoring devices

#### Postcondition

- KVO rate infusion

**Main Success Scenario**

1. ICE app determines that a patient-hazard may be occurring
2. ICE app issues alarm which displays and sounds on the ICE supervisor user interface
3. ICE app signals PCA pump to switch to KVO infusion rate
4. PCA pump switches to KVO infusion rate
5. PCA pump signals ICE app that it has switched to KVO rate infusion
6. Display “Hazard Detected by ICE app, pump rate=KVO”

**4.1.5 Use Case: Resume Operation After ICE-Detected Hazard (UC5)**

This use case describes operation when the infusion rate had been switched to KVO because an ICE app determined a hazard may exist, and the clinician has determined it is safe to return to normal operation.

**Related System Goals G1**

**Primary Actor** Clinician

**Precondition**

- ICE app determined a hazard may exist
- Clinician notified of hazard by alarm on ICE supervisor user interface
- PCA pump switched to KVO infusion rate

**Postcondition**

- Normal operation resumed

**Main Success Scenario**

1. Clinician checks patient vital signs
2. Clinician determines it is safe to resume prescribed infusion, or stops pump
3. Clinician clears ICE app-generated alarm on ICE supervisor user interface
4. ICE app signals PCA pump to resume prescribed infusion
5. PCA pump resumes prescribed infusion
6. PCA pump signals ICE app and control panel of resumption
7. ICE app indicates normal operation has resumed on ICE supervisor user interface

#### 4.1.6 Use Case: Audible Alarm Inactivation (UC6)

The control panel, an app running on the ICE supervisor, or a clinician via the supervisor user interface, may inactive audible alarm indication either temporarily or indefinitely.

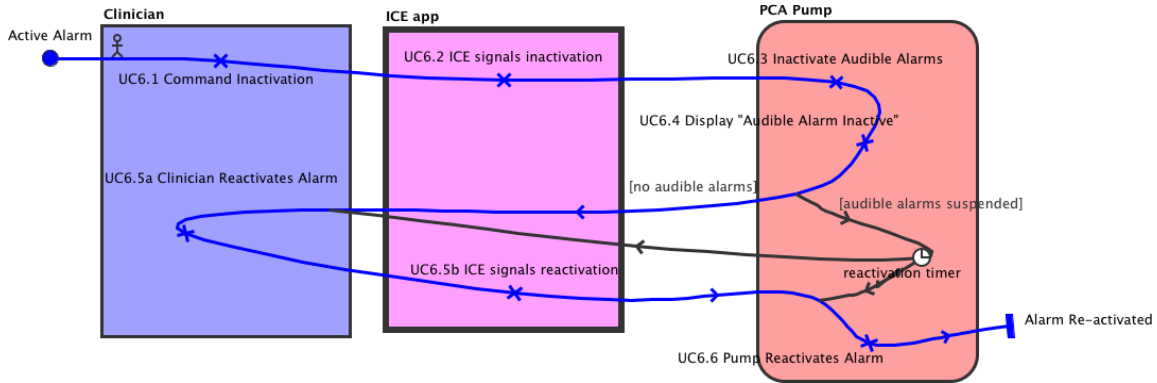

Figure 10: Use Case 6, Audible Alarm Inactivation

#### Related System Goals G3

**Primary Actor** Clinician or App

**Precondition** Normal operation

#### Postcondition

- Audible alarm on PCA pump inactivated;
- Visual indication of audible alarm inactivation

#### Main Success Scenario

1. Clinician using ICE supervisor user interface, or control panel, tells device to inactivate audible alarms either temporarily or indefinitely
2. ICE, or control panel, signals PCA pump to inactivate audible alarm
3. PCA pump inactivates audible alarms
4. PCA pump indicates audible alarm inactivation to both ICE and control panel
5. If temporary, alarm reactivates after alarm pause duration  $\Delta_{ap} = 10$  minutes
6. Clinician may reactivate audible alarm from either supervisor user interface or control panel

#### Alternate Success Scenario

All alarms and warnings are cancelled upon pressing the stop button.



#### **4.1.7 Use Case: Resume Infusion After Stop (UC7)**

Resume infusion after stop. (See Figures 3 and 4)

##### **Related System Goals**

**Primary Actor** Clinician

**Precondition** Infusion Halted by Stop Button

**Postcondition** Resume previous normal operation

##### **Main Success Scenario**

1. Clinician presses Start Button
2. Previous normal operation resumes

#### 4.1.8 Use Case: Flush (UC8)

Flush drug from pump after removal of needle before turning off.

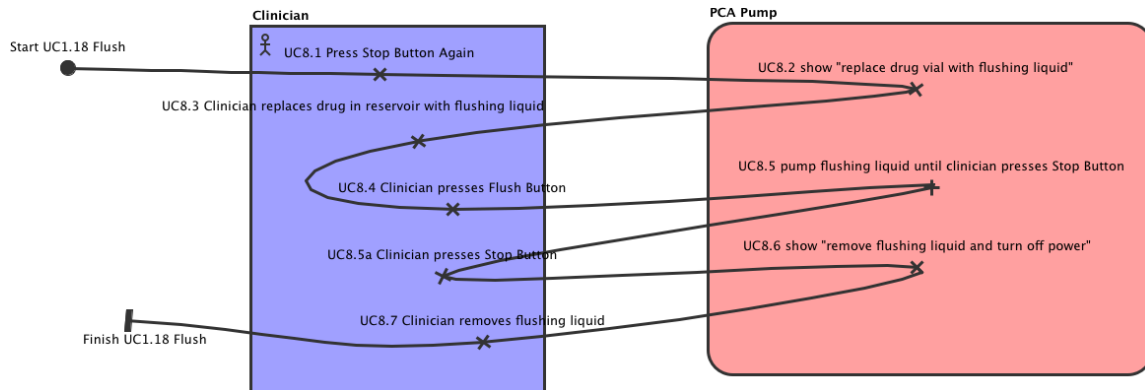

Figure 11: Use Case 8: Flush Pump

#### Related System Goals

**Primary Actor** Clinician

#### Precondition

- Infusion Halted by Stop Button
- Needle Removed From Patient
- Infusion Tube Removed From Pump

**Postcondition** Drug Flushed from Pump

#### Main Success Scenario

1. Clinician presses Stop Button again
2. Message displayed to replace drug vial with flushing liquid
3. Clinician removes current drug in reservoir
4. Clinician scans drug to be used for flush and checks that it is correct
5. Clinician places flush liquid into the reservoir
6. Clinician presses Flush Button
7. Pump flushing liquid until Clinician presses Stop Button
8. Message displayed to remove flushing liquid, then turn off power
9. Clinician removes flushing liquid

#### 4.1.9 Use Case: Prime Pump (UC9)

Pump drug through tube and needle to expel any residual air after loading drug into reservoir.

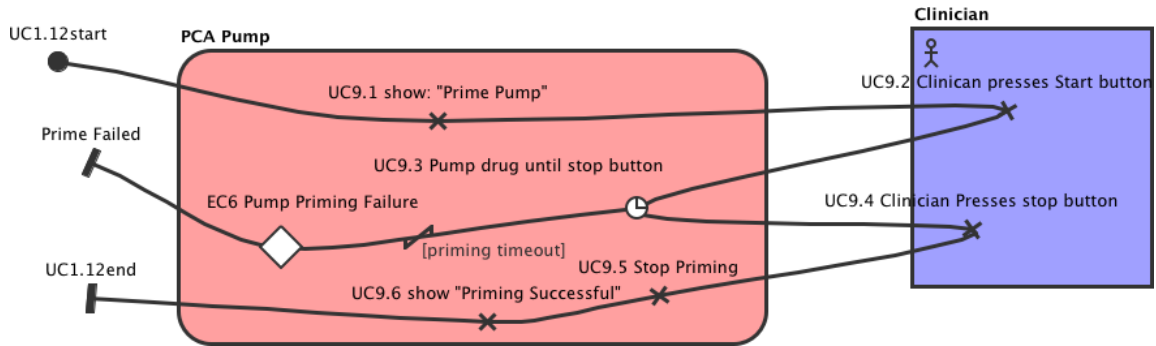

Figure 12: Use Case 9: Prime Pump

#### Related System Goals

**Primary Actor** Clinician

#### Precondition

- Infusion Halted by Stop Button
- Needle Removed From Patient
- Infusion Tube Removed From Pump

**Postcondition** Drug Flushed from Pump

#### Main Success Scenario

1. Message displayed to start priming
2. Clinician presses Start Button
3. Pump drug until Clinician presses Stop Button (time-out Exception Case: Pump Priming Failure)
4. Clinician presses Stop Button before priming time-out
5. Stop pumping
6. Message displayed that priming was successful

## 4.2 Exception Cases

The following exception cases describe unusual situations and the PCA pump's behavior for them. A summary of exception cases is provided in Table 2.

Table 2: Summary of PCA Exception Cases

<b>ID</b>	<b>Actor</b>	<b>Title</b>	<b>Description</b>
EC1	Patient or Clinician	Bolus Request Too Soon	bolus request denied because minimum time between boluses had not elapsed
EC2	Clinician	Drug Library Soft Limit	basal rate or bolus VTBI exceeded soft limit
EC3	Clinician	Drug Library Hard Limit	basal rate or bolus VTBI exceeded hard limit
EC4		Power-On Self Test Failure	power-on self test fails
EC5		Internal Electronic Failure	PCA pump detects its own failure
EC6	Clinician	Pump Priming Failure	pump fails to prime after loading drug reservoir
EC7		Over-Flow Rate Alarm	measured flow rate exceeds setting
EC8		Under-Flow Rate Alarm	measured flow rate below setting
EC9		Pump Overheating	pump temperature exceeds 55 C
EC10		Downstream Occlusion	blockage between pump and patient
EC11		Upstream Occlusion	blockage between reservoir and pump
EC12		Air-in-line Embolism	bubble detection
EC13		Maximum Safe Dose	dose reaches maximum allowed by drug library
EC14	Clinician	Clinician Authentication Failure	clinician not authorized to operate pump
EC15	Clinician	Patient Authentication Failure	patient not admitted to hospital
EC16	Clinician	Prescription Authentication Failure	drug or prescription not intended for this patient
EC17	Clinician	Sound Failure	no audible alarm
EC18		ICE Failure	indication of no ICE alarms enabled
EC19		Drug Library Not Present or Corrupted	the drug library fails authenticity or integrity check
EC20		Reservoir Low	little drug remaining
EC21		Reservoir Empty	no drug remaining
EC22		Diagnostic Detected Hazards	battery or power supply reservoir door open, self tests continuous fault detection fault masking, failure LED
EC23	Clinician	Alert-Stop-Sequence	repeated warning or alarm
EC24	Clinician	Inactivity Timeout	long pause after authentication

**4.2.1 Exception Case: Bolus Request Too Soon (EC1)**

A bolus is requested prior to prescribed minimum time elapsing between boluses.

**Related System Goals** G2 and G3

**Primary Actor** Patient or Clinician

**Precondition** Patient received recent bolus

**Postcondition** No bolus infused

**Exception Success Scenario**

1. Check of minimum time between boluses fails (Use Cases: Patient-Requested Bolus or Clinician-Requested Bolus)
2. Control Panel and ICE supervisor user interface (if connected) issue audible warning and display visual warning
3. Warning recorded in Fault Log

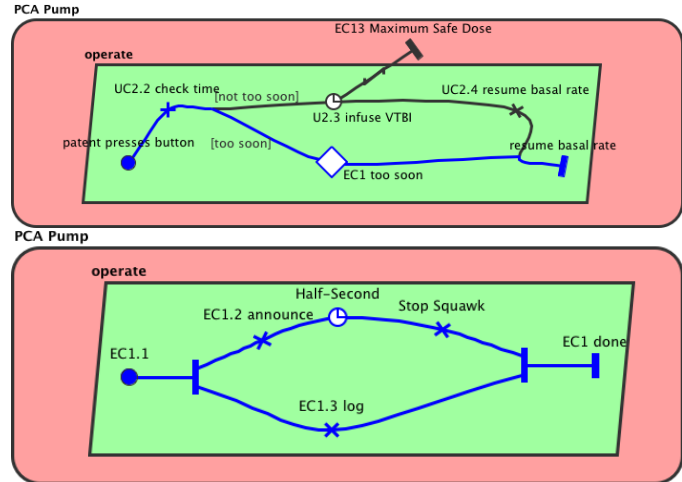

Figure 13: Exception Case 1, Bolus Request Too Soon

#### 4.2.2 Exception Case: Drug Library Soft Limit (EC2)

Programmed or prescribed basal rate or bolus VTBI exceeds Drug Library soft limits.

**Related System Goals** G2 and G3

**Primary Actor** Clinician

**Precondition** Drug library loaded into PCA pump by pharmacy

**Postcondition** Either

- Clinician sets infusion rate within soft limits, or
- Clinician explicitly authorizes infusion rate exceeding soft limits

#### Exception Success Scenario

1. Detection that entered infusion rate exceeded soft limit of drug library by
  - less volume than VTBI Lower Soft limit
  - more volume than VTBI Upper Soft limit
  - smaller infusion rate than Basal Rate Lower Soft limit
  - greater infusion rate than Basal Rate Upper Soft limit
2. Warning sound and message on Control Panel and ICE supervisor user interface
3. Attempt to exceed soft limit recorded in Event Log
4. Clinician confirms or rejects VTBI or basal rate
  - If confirmed, programmed or prescribed rate used for infusion
  - if rejected, typical VTBI or basal rate from Drug Library used for infusion
5. Clinician confirmation or rejection recorded in Event Log

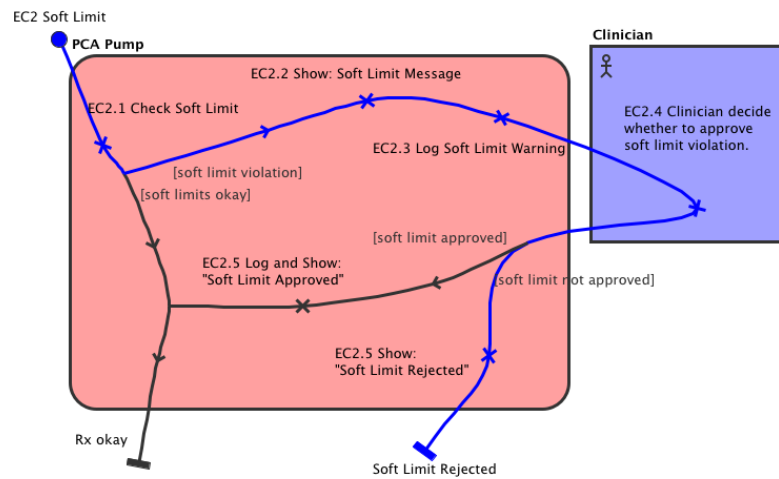

Figure 14: Exception Case 2, Drug Library Soft Limit

### 4.2.3 Exception Case: Drug Library Hard Limit (EC3)

Programmed or prescribed basal rate or VTBI exceeds Drug Library hard limits.

**Related System Goals** G2, G3 and G5

**Primary Actor** Clinician

**Precondition** Drug library loaded into PCA pump by pharmacy

**Postcondition** Either

- Typical VTBI or basal rate from Drug Library used for infusion, or
- Clinician sets infusion rate within hard limits

#### Exception Success Scenario

1. Detection that entered infusion rate exceeded hard limit of drug library by
  - less volume than VTBI Lower Hard limit
  - more volume than VTBI Upper Hard limit
  - smaller infusion rate than Basal Rate Lower Hard limit
  - greater infusion rate than Basal Rate Upper Hard limit
2. Warning sound and message on Control Panel and ICE supervisor user interface
3. Typical VTBI or basal rate from Drug Library used for infusion
4. Attempt to exceed hard limit recorded in Fault Log
5. Clinician may try to program rate not exceeding hard limit

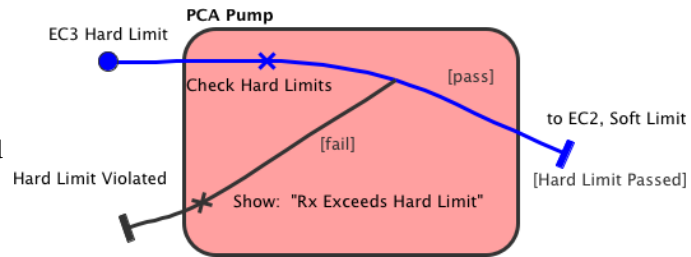

Figure 15: Exception Case 3, Drug Library Hard Limit



**4.2.4 Exception Case: Power-On Self Test Failure (EC4)**

Power-on self test (POST) fails.

**Related System Goals** G5

**Primary Actor** none

**Precondition**

- PCA pump connected to mains power
- PCA pump turned on

**Postcondition**

- Alarm sounded and displayed
- Infusion inhibited

**Exception Success Scenario**

1. POST fails
2. Alarm sounded and displayed by Control Panel and ICE supervisor user interface
3. Failure recorded in Fault Log
4. All infusion inhibited.

#### 4.2.5 Exception Case: Internal Electronic Failure (EC5)

Memory fails, processor fails, thread monitor fails, power supply fails, or battery fails during operation.

**Related System Goals** G5

**Primary Actor** none

**Precondition** normal operation

**Postcondition**

- Alarm sounded and displayed
- Infusion rate switched to KVO or halted

**Exception Success Scenario**

1. Electronic fault detected
  - Random-access memory fault, issue *RAM failure alarm*
  - Read-only memory fault, issue *ROM failure alarm*
  - Microprocessor fault, issue *CPU failure alarm*
  - Thread monitor fault, issue *thread monitor alarm*
  - Battery failure, issue *battery failure alarm*
  - Power supply voltage our of range, issue *voltage out-of-range alarm*
2. Alarm sounded and displayed by Control Panel and ICE supervisor user interface
3. Failure recorded in Fault Log
4. Infusion halted or switched to infusion rate in Table 4 PCA Pump Alarm Priority and Alarm Pump Rate.

#### 4.2.6 Exception Case: Pump Priming Failure (EC6)

Pump fails to prime indicated by time-out while priming.

**Related System Goals** G5

**Primary Actor** Clinician

**Precondition**

- Drug loaded into reservoir
- Door Closed
- Tube attached

**Postcondition**

- Alarm sounded and displayed
- Infusion inhibited

**Exception Success Scenario**

1. Pump priming failure detected by time-out
2. *priming failure alarm* sounded and displayed by Control Panel and ICE supervisor user interface
3. Failure recorded in Fault Log
4. No infusion allowed

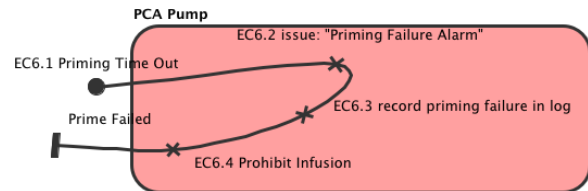

Figure 16: Exception Case 6, Priming Failure

#### 4.2.7 Exception Case: Over-Flow Rate Alarm (EC7)

Measured drug flow rate exceeds programmed value by more than allowed tolerance.

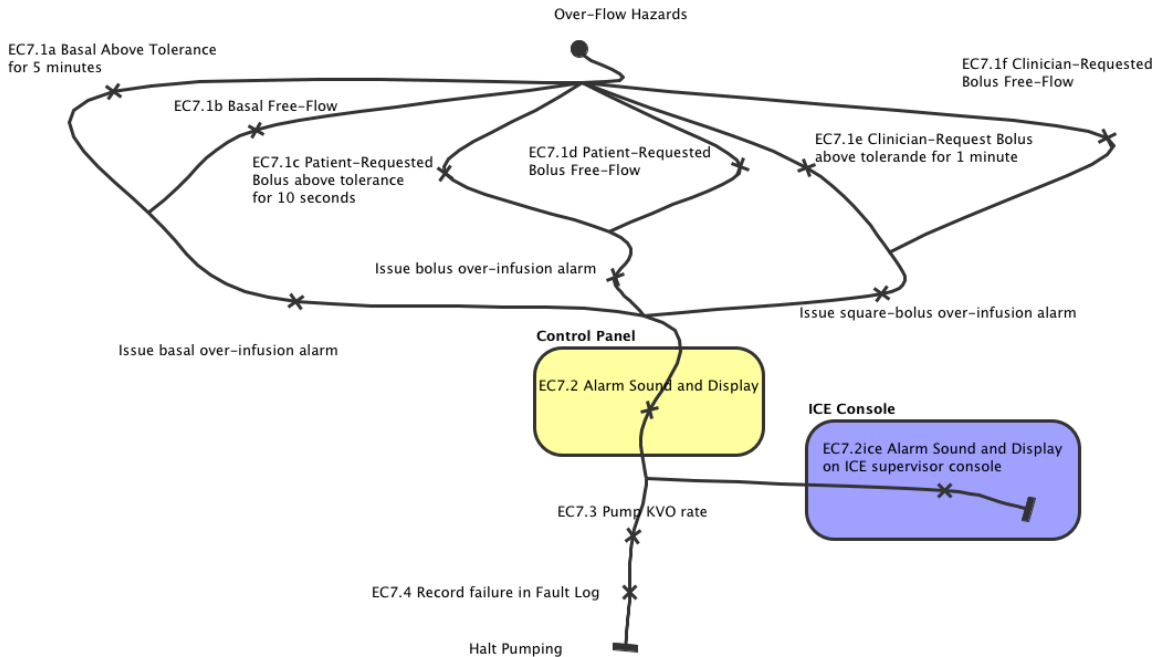

Figure 17: Exception Case 7, Over-Flow Rate Alarm

#### Related System Goals G5

**Primary Actor** none

**Precondition** normal operation

#### Postcondition

- Alarm sounded and displayed
- Infusion halted

#### Exception Success Scenario

1. Measured drug flow rate
  - a) basal flow rate exceeds prescribed basal flow rate by more than its allowed tolerance over a period of more than 5 minutes, issue *basal over-infusion alarm*
  - b) basal flow rate goes into free flow, issue *basal over-infusion alarm* immediately
  - c) patient-requested bolus flow rate exceeds the prescribed patient-requested bolus rate setting by more than its allowed tolerance over a period of more than 10 seconds the pump shall issue a *bolus over-infusion alarm*

- d) patient-requested bolus flow rate goes into free flow, issue a *bolus over-infusion alarm* immediately
  - e) clinician-requested bolus flow rate exceeds the prescribed patient-requested bolus rate setting by more than its allowed tolerance over a period of more than 1 minutes the pump shall issue a *square bolus over-infusion alarm*
  - f) clinician-requested bolus flow rate goes into free flow, issue a *square bolus over-infusion alarm* immediately
2. Alarm sounded and displayed by Control Panel and ICE supervisor user interface
  3. Pump at KVO rate
  4. Failure recorded in Fault Log

#### 4.2.8 Exception Case: Under-Flow Rate Warning (EC8)

Measured drug flow rate is less than programmed value by more than allowed tolerance.

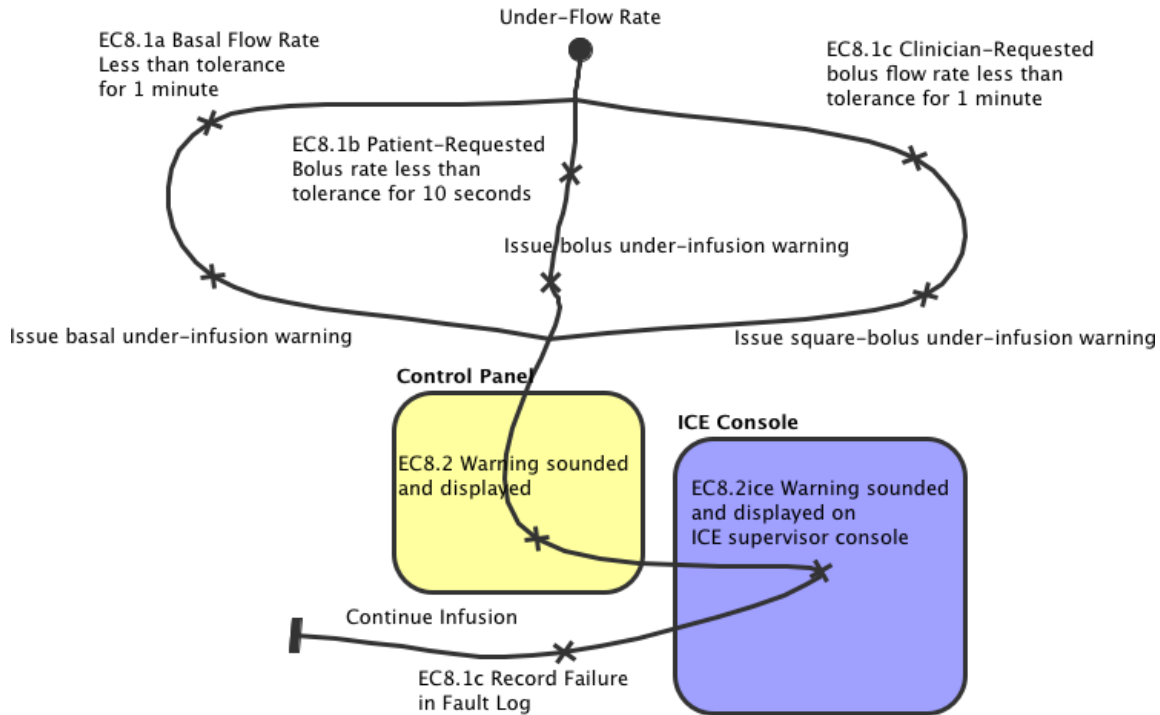

Figure 18: Exception Case 8, Under-Flow Rate Warning

#### Related System Goals G5

**Primary Actor** none

**Precondition** normal operation

**Postcondition** Alarm sounded and displayed

#### Exception Success Scenario

1. Measured drug flow rate
  - a) basal flow rate is less than prescribed basal flow rate by more than its allowed tolerance over a period of more than 5 minutes, issue *basal under-infusion warning*
  - b) patient-requested bolus flow rate is less than the prescribed patient-requested bolus rate by more than its allowed tolerance over a period of more than 10 seconds the pump shall issue a *bolus under-infusion warning*
  - c) clinician-requested bolus flow rate is less than the prescribed patient-requested bolus rate setting by more than its allowed tolerance over a period of more than 1 minutes

the pump issues a *square bolus under-infusion warning*

2. Warning sounded and displayed by Control Panel and ICE supervisor user interface
3. Failure recorded in Fault Log

#### 4.2.9 Exception Case: Pump Overheating (EC9)

Pump temperature exceeds limit.

**Related System Goals** G5

**Primary Actor** none

**Precondition** normal operation

**Postcondition**

- Alarm sounded and displayed
- Infusion halted

**Exception Success Scenario**

1. Pump temperature exceeds 55 C, issue *pump overheated alarm*
2. Alarm sounded and displayed by Control Panel and ICE supervisor user interface
3. Pumping halted
4. Failure recorded in Fault Log

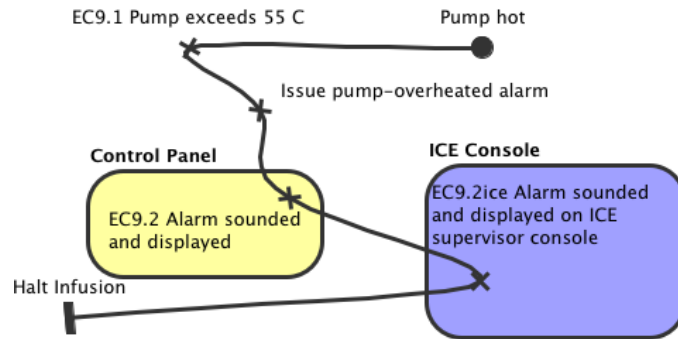

Figure 19: Exception Case 9, Pump Overheating



**4.2.10 Exception Case: Downstream Occlusion (EC10)**

Blockage detected between pump and patient.

**Related System Goals** G5

**Primary Actor** none

**Precondition** normal operation

**Postcondition**

- Alarm sounded and displayed
- Infusion halted

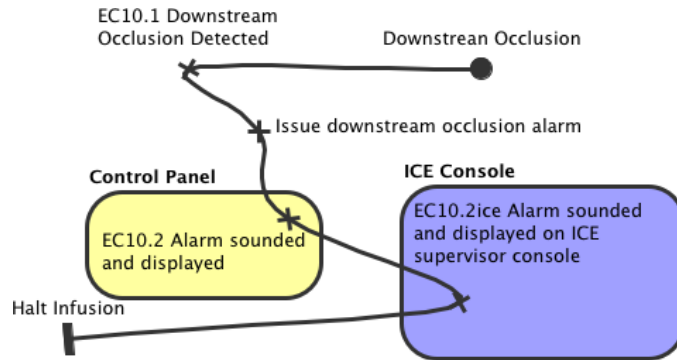

Figure 20: Exception Case 10, Downstream Occlusion

**Exception Success Scenario**

1. Downstream occlusion detected, issue *downstream occlusion alarm*
2. Alarm sounded and displayed by Control Panel and ICE supervisor user interface
3. Pumping halted
4. Failure recorded in Fault Log

**4.2.11 Exception Case: Upstream Occlusion (EC11)**

Blockage detected between pump and patient.

**Related System Goals** G5

**Primary Actor** none

**Precondition** normal operation

**Postcondition**

- Alarm sounded and displayed
- Infusion halted

**Exception Success Scenario**

1. Upstream occlusion detected, issue *upstream occlusion alarm*
2. Alarm sounded and displayed by Control Panel and ICE supervisor user interface
3. Pumping halted
4. Failure recorded in Fault Log

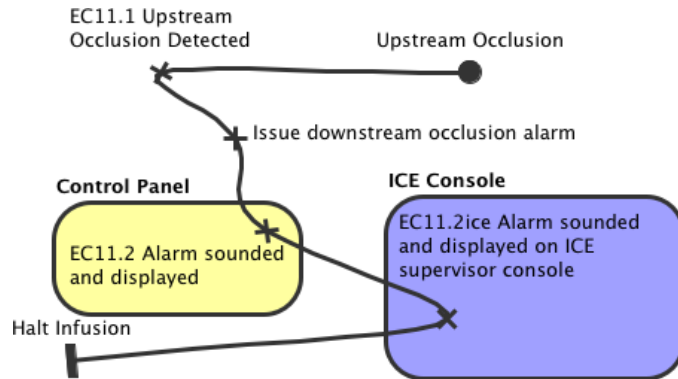

Figure 21: Exception Case 11, Upstream Occlusion

**4.2.12 Exception Case: Air-in-line Embolism (EC12)**

Air-in-line embolism (bubble) detected between pump and patient.

**Related System Goals** G4

**Primary Actor** none

**Precondition** normal operation

**Postcondition**

- Alarm sounded and displayed
- Infusion halted

**Exception Success Scenario**

1. Air-in-line embolism detected, issue *air-in-line embolism alarm*
2. Alarm sounded and displayed by Control Panel and ICE supervisor user interface
3. Pumping halted
4. Failure recorded in Fault Log

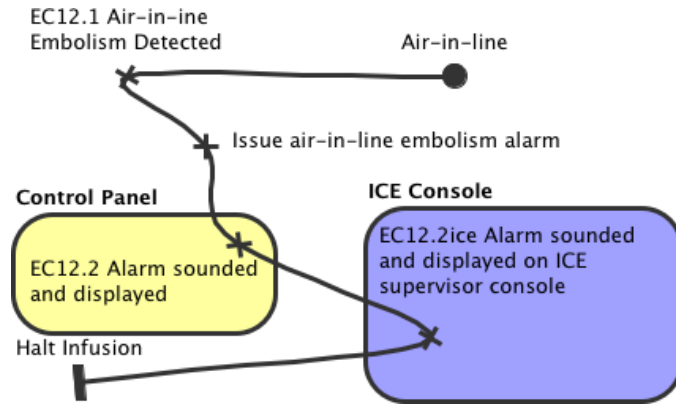

Figure 22: Exception Case 12, Air-in-line Embolism

**4.2.13 Exception Case: Maximum Safe Dose (EC13)**

Maximum dose of drug over period of time allowed by Drug Library reached.

**Related System Goals** G2

**Primary Actor** none

**Precondition** normal operation

**Postcondition**

- Alarm sounded and displayed
- Infusion switched to KVO rate

**Exception Success Scenario**

1. Total drug dose for period of time in Drug Library exceeded, issue *max dose warning*
2. Warning sounded and displayed by Control Panel and ICE supervisor user interface
3. Infusion switched to KVO rate
4. Event recorded in Fault Log and Event Log

**4.2.14 Exception Case: Clinician Authentication Failure (EC14)****Related System Goals G6****Primary Actor** Clinician**Precondition**

- Clinician badge scanned
- Information from badge fails authentication

**Postcondition**

- Display clinician authentication failure on Control Panel and ICE supervisor user interface
- Record clinician authentication failure in Event Log
- Inhibit pump operation

**Exception Success Scenario**

1. Pump cannot be operated by unauthorized person

**4.2.15 Exception Case: Patient Authentication Failure (EC15)****Related System Goals G6****Primary Actor** Clinician**Precondition**

- Patient wristband scanned
- Information from wristband fails authentication

**Postcondition**

- Display patient authentication failure on Control Panel and ICE supervisor user interface
- Record patient authentication failure in Event Log
- Inhibit pump operation

**Exception Success Scenario**

1. Pump can only be used on admitted patients

**Special Case**

- In the event that the PCA Pump is unable to identify the patient (due to an issue with the patient's wristband, etc.), it may be necessary to allow authorization of a temporarily "Unidentified Patient" record to continue healthcare, and require clinicians to reconcile the discrepancy later.

**4.2.16 Exception Case: Prescription Authentication Failure (EC16)****Related System Goals G6****Primary Actor** Clinician**Precondition**

- Drug container label scanned
- Information from label fails authentication

**Postcondition**

- Display prescription authentication failure on Control Panel and ICE supervisor user interface
- Record prescription authentication failure in Event Log
- Inhibit pump operation

**Exception Success Scenario**

1. Pump may only administer drug to the patient for which it was prescribed

**4.2.17 Exception Case: Sound Failure (EC17)****Related System Goals G5****Primary Actor** Clinician**Precondition**

- PCA pump plugged-in and turned-on
- Clinician (normal hearing) in room, nearby

**Postcondition**

- Display sound failure on Control Panel and ICE supervisor user interface
- Record sound failure in Event Log
- Inhibit pump operation

**Exception Success Scenario**

1. Pump may only administer drug to the patient when audible alarms can alert clinician(s) to a possibly-hazardous condition.



**4.2.18 Exception Case: ICE Failure (EC18)**

The control panel will visually indicate when the PCA pump is not connected to an operational ICE. When the ICE network or manager fails, all alarms are reactivated, and is indicated visually on the control panel.

**Related System Goals** G3

**Primary Actor** PCA pump

**Precondition** PCA pump plugged-in and turned-on

**Postcondition**

- Lack of ICE connection indicated on control panel
- All alarms enabled

**4.2.19 Exception Case: Drug Library Not Present or Corrupted (EC19)**

The Drug Library is absent, corrupted, or incorrectly authenticated.

**Related System Goals** G2, G3 and G5

**Primary Actor** none

**Precondition** normal operation

**Postcondition**

- Alarm sounded and displayed
- Infusion halted

**Exception Success Scenario**

1. Alarm sounded and displayed by Control Panel and ICE supervisor user interface
2. Pumping halted
3. Failure recorded in Fault Log

**4.2.20 Exception Case: Reservoir Low (EC20)**

Remaining drug falls below reservoir low limit.

**Related System Goals** G1

**Primary Actor** none

**Precondition** normal operation

**Postcondition** Warning sounded and displayed; pump rate limited to basal rate

**Exception Success Scenario**

1. Remaining volume of drug falls below a reservoir low limit, either measured or determined
2. Warning sounded and displayed by Control Panel and ICE supervisor user interface
3. Pump rate limited to basal rate
4. Occurrence recorded in Fault Log

**4.2.21 Exception Case: Reservoir Empty (EC21)**

Remaining drug falls below reservoir empty limit.

**Related System Goals** G1

**Primary Actor** none

**Precondition** low drug (EC20)

**Postcondition** Alarm sounded and displayed; pumping halted

**Exception Success Scenario**

1. Remaining volume of drug falls below a reservoir empty limit, either measured or determined
2. Alarm sounded and displayed by Control Panel and ICE supervisor user interface
3. Pumping halted
4. Occurrence recorded in Fault Log

#### 4.2.22 Exception Case: Diagnostic Detected Hazards (EC22)

Internal diagnostics detect a hazard.

**Related System Goals** G1

**Primary Actor** none

**Precondition** normal operation

**Postcondition** depends on hazard

**Exception Success Scenarios**

- a) **power supply** Because with either working battery or power supply can operate the pump, if the battery failure alarm and either the voltage out-of-range or the power supply failure alarms, then the pump rate will be off, otherwise the pump rate will continue at its previous value.
- b) **reservoir door** An open door alarm is triggered when the reservoir door is opened while the pump is not stopped.
- c) **self tests** Perform periodic self-tests to assure system integrity during long periods of use. Failure of a self-test shall raise a self-test alarm, stop pump, record it in the Fault Log, and display the reason for failure on the user interface.
- d) **continuous fault detection** Continuously monitor faults.
- e) **masked faults** Faults may be masked, but must be recorded.
- f) **failure LED** Faults that cannot be displayed on the Control Panel will illuminate a LED indicating failure.

In all cases log the fault, raise alarm and change pump rate if warranted.

**4.2.23 Exception Case: Alert-Stop-Start Sequence (EC23)**

Repeated alert (alarm or warning) followed by attempt to resume infusion indicate a serious problem such as downstream occlusion. Therefore alert-stop-start sequences are limited.

**Related System Goals** G1

**Primary Actor** clinician

**Precondition** normal operation

**Postcondition** pumping halted

**Exception Success Scenario**

If the same alert-stop-start sequence occurs 3 or more times in ten minutes, infusion will be stopped, and an audible alarm sounded.

#### 4.2.24 Exception Case: Inactivity Timeout (EC24)

Inactivity following clinician authentication indicates that the clinician may have been called away, thus requiring re-authentication.

##### **Related System Goals**

**Primary Actor** clinician

**Precondition** clinician authenticated and action expected

**Postcondition** require new clinician authentication

##### **Exception Success Scenario**

During initialization, following clinician authentication (UC1.4 §4.1.1) and before start of infusion (UC1.14), inactivity of  $T_{to} = 3$  minutes will restart initialization at clinician authentication. Display "inactivity timeout" for  $T_{dt} = 3$  seconds.

Similarly, following clinician authentication for clinician requested bolus (UC3.2 §4.1.3) and before its commencement, (UC3.5) inactivity of  $T_{to} = 3$  minutes will require new clinician authentication.

**Part II**  
**Requirements**



## 5 PCA Pump Function

The PCA pump infuses at prescribed basal, bolus, or KVO rates.

### 5.1 Basal Flow Rate

- (1) The *basal flow rate*<sup>16</sup>,  $F_{basal}$ , is prescribed by a physician, and entered into the PCA pump by scanning the prescription from the drug container label as it is loaded into the reservoir. (UC1.7 §4.1.1)
- (2) The pump shall be able to deliver basal infusion at flows throughout the *basal infusion flow range*<sup>17</sup> of  $F_{basal\ min} = 1$  to  $F_{basal\ max} = 10$  ml/hr. (UC1 §4.1.1)
- (3) The pump shall deliver basal infusion at the prescribed basal rate within a *basal infusion flow tolerance*<sup>18</sup> of  $F_{basal\ tol} = 0.5$  ml/hr of the prescribed basal rate. (UC1.12 §4.1.1)
- (4) Any *alarm stops basal rate*<sup>19</sup> delivery either halting pump or switching to KVO rate as defined in Table 4. (many EC)
- (5) The pump shall maintain a *minimum KVO flow rate*<sup>20</sup> of  $F_{KVO} = 1$  ml/hr at all times during infusion, even during alarms, unless the alarm also stops flow, or the stop button is pressed. Table 4 defines which alarms also stop drug flow completely. (EC7.4 §4.2.7)

### 5.2 Patient-Requested Bolus

- (1) Upon patient's press of the PCA pump's patient-button, a prescribed bolus volume-to-be-infused, *VTBI*, of the drug loaded in the pump is delivered to the patient.<sup>21</sup> (UC2 §4.1.2)
- (2) A *patient-requested bolus*<sup>22</sup> shall be delivered at its prescribed rate,  $F_{bolus}$ , in addition to the prescribed basal flow rate,  $F_{basal}$ , but no more than the maximum flow rate for the pump,  $F_{max}$ . (UC2.3 §4.1.2)
- (3) Patient-requested bolus shall not be delivered more often than a prescribed *minimum time between patient-requested bolus*<sup>23</sup>,  $\Delta_{prb}$ . (UC2.2 §4.1.2)
- (4) Prescribed *VTBI* and rate shall not exceed the *maximum VTBI*<sup>24</sup> limit set by the drug library from the hospital pharmacy for the drug loaded in the PCA pump. (EC3 §4.2.3)

---

<sup>16</sup>requirement R5.1.0(1): *basal flow rate*

<sup>17</sup>requirement R5.1.0(2): *basal infusion flow range*

<sup>18</sup>requirement R5.1.0(3): *basal infusion flow tolerance*

<sup>19</sup>requirement R5.1.0(4): *alarm stops basal rate*

<sup>20</sup>requirement R5.1.0(5): *minimum KVO flow rate*

<sup>21</sup>Subject to safety constraints.

<sup>22</sup>requirement R5.2.0(2): *patient-requested bolus*

<sup>23</sup>requirement R5.2.0(3): *minimum time between patient-requested bolus*

<sup>24</sup>requirement R5.2.0(4): *maximum VTBI*

- (5) Patient-requested bolus shall *not* be delivered if infusing prescribed *VTBI* will exceed hard limits retrieved from the drug library for the volume of drug infused over a period of time. Pump rate shall be reduced to KVO and a *max dose warning*<sup>25</sup> be issued. (EC13 §4.2.13)
- (6) Any *alarm stops patient-requested bolus*<sup>26</sup> delivery either halting pump or switching to KVO rate as defined in Table 4. (many EC)

### 5.3 Clinician-Requested Bolus

- (1) A clinician observing the discomfort of the patient may command the PCA pump to deliver a *square bolus* of the same volume-to-be-infused, *VTBI*, as patient-requested bolus over a period of time chosen by the clinician.<sup>27</sup> (UC3 §4.1.3)
- (2) A *clinician-requested bolus*<sup>28</sup> shall be delivered at the rate,  $F_{ccb}$ , of *VTBI* divided by the duration chosen by the clinician,  $\Delta_{ccb}$ , in addition to the prescribed basal flow rate,  $F_{basal}$ , but no more than the maximum flow rate for the pump,  $F_{max}$ . (UC3.3 §4.1.3)

$$F_{ccb} = \min(VTBI/\Delta_{ccb} + F_{basal}, F_{max})$$

- (3) A *patient-requested bolus takes precedence*<sup>29</sup> over a clinician-requested bolus. The clinician-requested bolus shall be suspended while the patient-requested bolus dose is administered, and resumed afterward. (UC3.3 §4.1.3)
- (4) Any *alarm halts clinician-requested bolus*<sup>30</sup> delivery either halting pump or switching to KVO rate as defined in Table 4. (many EC)
- (5) The *maximum clinician-chosen duration*<sup>31</sup> for a clinician-requested bolus shall be  $\Delta_{ccb\ max} = 6$  hours.
- (6) The *minimum clinician-chosen duration*<sup>32</sup> for a clinician-requested bolus shall be the prescribed minimum number of minutes between consecutive patient-requested bolus deliveries,  $\Delta_{prb}$ .
- (7) Clinician-commanded bolus shall be halted when continuing to infuse exceeds prescribed volume of drug infused over a period of time (ml/hr). Pump rate shall be reduced to KVO and a *max dose warning*<sup>33</sup> be issued. (EC13 §4.2.13)

---

<sup>25</sup>requirement R5.2.0(5): *max dose warning*

<sup>26</sup>requirement R5.2.0(6): *alarm stops patient-requested bolus*

<sup>27</sup>The prescription is determined by a physician. Duration for clinician-requested bolus is one of the few parameters chosen by the clinician.

<sup>28</sup>requirement R5.3.0(2): *clinician-requested bolus*

<sup>29</sup>requirement R5.3.0(3): *patient-requested bolus takes precedence*

<sup>30</sup>requirement R5.3.0(4): *alarm halts clinician-requested bolus*

<sup>31</sup>requirement R5.3.0(5): *maximum clinician-chosen duration*

<sup>32</sup>requirement R5.3.0(6): *minimum clinician-chosen duration*

<sup>33</sup>requirement R5.3.0(7): *max dose warning*

## 6 PCA Pump Interfaces

### 6.1 Sensors

- (1) The PCA pump shall *measure drug flow*<sup>34</sup> within a tolerance of  $F_{mdf\ tol} = 0.1$  ml/hr. (many EC)
- (2) The PCA pump shall *detect downstream occlusion*<sup>35</sup>. (EC10 §4.2.10)
- (3) The PCA pump shall *detect upstream occlusion*<sup>36</sup>. (EC11 §4.2.11)
- (4) The PCA pump shall *detect air-in-line embolism*<sup>37</sup> (bubble). (EC12 §4.2.12)

### 6.2 Actuators

- (1) The mechanical pump shall *pump drug*<sup>38</sup> at prescribed flow rates for basal, bolus, and KVO infusion when commanded. (UC1 §4.1.1 UC2 §4.1.2 UC3 §4.1.3)
- (2) The mechanical pump shall *halt pumping*<sup>39</sup> when commanded, or caused in response to an alarm condition.(many EC)
- (3) The mechanical pump shall not allow *reverse flow*<sup>40</sup> from the patient into the pump. (FDA ??)

### 6.3 Device Parameters

- (1) The PCA pump shall use a physician's prescription as *device parameters*<sup>41</sup>. (UC1 §4.1.1 UC2 §4.1.2 UC3 §4.1.3)

### 6.4 Alarms

- (1) The PCA pump shall *issue alarms and warnings*<sup>42</sup> that require clinician attention. (many EC)
- (2) If delivered basal flow rate exceeds the prescribed basal rate setting by more than its allowed tolerance over a period of more than 5 minutes, or immediately if the pump goes into free flow, the pump shall issue an *basal over-infusion alarm*<sup>43</sup> (EC7 §4.2.7).

<sup>34</sup>requirement R6.1.0(1): *measure drug flow*

<sup>35</sup>requirement R6.1.0(2): *detect downstream occlusion*

<sup>36</sup>requirement R6.1.0(3): *detect upstream occlusion*

<sup>37</sup>requirement R6.1.0(4): *detect air-in-line embolism*

<sup>38</sup>requirement R6.2.0(1): *pump drug*

<sup>39</sup>requirement R6.2.0(2): *halt pumping*

<sup>40</sup>requirement R6.2.0(3): *reverse flow*

<sup>41</sup>requirement R6.3.0(1): *device parameters*

<sup>42</sup>requirement R6.4.0(1): *issue alarms and warnings*

<sup>43</sup>requirement R6.4.0(2): *basal over-infusion alarm*

- (3) If delivered basal flow rate is less than the prescribed basal rate setting by more than its allowed tolerance over a period of more than 5 minutes, or immediately if the flow stops, the pump shall issue an *basal under-infusion warning*<sup>44</sup> (EC4.2.8).
- (4) If delivered patient-requested bolus flow rate exceeds the prescribed patient-requested bolus rate setting by more than its allowed tolerance over a period of more than 1 minutes, or immediately if the pump goes into free flow, the pump shall issue a *bolus over-infusion alarm*<sup>45</sup> (EC4.2.7).
- (5) If delivered patient-requested bolus flow rate is less than the prescribed bolus rate setting by more than its allowed tolerance over a period of more than 1 minutes, or immediately if the flow stops, the pump shall issue a *bolus under-infusion warning*<sup>46</sup> (EC4.2.8).
- (6) If delivered clinician-requested bolus flow rate exceeds the calculated square bolus rate by more than its allowed tolerance over a period of more than 5 minutes, or immediately if the pump goes into free flow, the pump shall issue a *square bolus over-infusion alarm*<sup>47</sup> (EC4.2.7).
- (7) If delivered clinician-requested bolus flow rate is less than the calculated square bolus rate by more than its allowed tolerance over a period of more than 5 minutes, or immediately if the flow stops, the pump shall issue a *square bolus under-infusion warning*<sup>48</sup> (EC4.2.8).
- (8) If the pump gets overheated to more than  $T_{poh} = 55$  C, the pump shall issue an *pump overheated alarm*<sup>49</sup> (EC4.2.9).

Other alarm conditions are described in Section 7, Safety Requirements.

#### 6.4.1 Alarm Priority

- (1) Alarm's and warning's *priority*<sup>50</sup> shall be determined in accordance with standard IEC 60601-1-8 *Medical electrical equipment - Part 1-8: General requirements for safety - Collateral standard: Alarm systems - General requirements, tests and guidance for alarm systems in medical electrical equipment and medical electrical systems*. Table 201 - Alarm Condition Priorities is reproduced as Table 3 for convenience. (IEC 60601-1-8 2.3.1)
- (2) Priority for alarms and warnings is shown in Table 4; warnings are low-priority alarms. The last column show the *alarm pump rate*<sup>51</sup> to be used while the alarm is in effect. For “special” flow rates for power malfunctions see Section 7.3.
- (3) Because with either working battery or power supply can operate the pump, if the battery failure alarm and either the voltage out-of-range or the power supply failure alarms, then the pump rate will be off, otherwise the pump rate will continue at its previous value.<sup>52</sup> (EC22 §4.2.22)

<sup>44</sup>requirement R6.4.0(3): *basal under-infusion warning*

<sup>45</sup>requirement R6.4.0(4): *bolus over-infusion alarm*

<sup>46</sup>requirement R6.4.0(5): *bolus under-infusion warning*

<sup>47</sup>requirement R6.4.0(6): *square bolus over-infusion alarm*

<sup>48</sup>requirement R6.4.0(7): *square bolus under-infusion warning*

<sup>49</sup>requirement R6.4.0(8): *pump overheated alarm*

<sup>50</sup>requirement R6.4.1(1): *priority*

<sup>51</sup>requirement R6.4.1(2): *alarm pump rate*

<sup>52</sup>requirement R6.4.1(3): *power and battery failure*

Table 3: Alarm Condition Priorities

Potential result of failure to respond to the cause of Alarm Condition	Onset of potential harm		
	Immediate	Prompt	Delayed
Death or irreversible injury	HIGH	HIGH	MEDIUM
Reversible injury	HIGH	MEDIUM	LOW
Minor injury or discomfort	MEDIUM	LOW	LOW or no ALARM SIGNAL

Table 4: PCA Pump Alarm Priority and Alarm Pump Rate

Alarm	Potential Harm	Harm Onset	Priority	Pump Rate
basal over-infusion alarm	death	immediate	HIGH	KVO
bolus over-infusion alarm	death	immediate	HIGH	KVO
square bolus over-infusion alarm	death	immediate	HIGH	KVO
alert-stop-start sequence	discomfort	immediate	MEDIUM	KVO
air-in-line alarm	minor injury	immediate	MEDIUM	off
empty-reservoir alarm	discomfort	immediate	MEDIUM	off
pump overheated alarm	discomfort	immediate	MEDIUM	off
downstream occlusion alarm	discomfort	immediate	MEDIUM	off
upstream occlusion alarm	discomfort	immediate	MEDIUM	off
POST failure alarm	discomfort	delayed	LOW	off
RAM failure alarm	discomfort	delayed	LOW	off
ROM failure alarm	discomfort	delayed	LOW	off
CPU failure alarm	discomfort	delayed	LOW	off
thread monitor alarm	discomfort	delayed	LOW	off
battery failure alarm	discomfort	delayed	LOW	special
voltage out-of-range alarm	discomfort	delayed	LOW	special
power supply failure alarm	discomfort	delayed	LOW	special
max dose warning	discomfort	delayed	LOW	KVO
basal under-infusion warning	discomfort	delayed	LOW	basal
bolus under-infusion warning	discomfort	delayed	LOW	bolus
square bolus under-infusion warning	discomfort	delayed	LOW	bolus
battery-backup warning	discomfort	delayed	LOW	previous
low-battery warning	discomfort	delayed	LOW	KVO
low-reservoir warning	discomfort	delayed	LOW	KVO
long pause warning	discomfort	delayed	LOW	KVO

### 6.4.2 Alarm Visual

Requirements for alarm visibility are derived from standard IEC 60601-1-8 section 201.3.2.2 *Characteristics of visual ALARM SIGNALS*

- (1) If a visual indicator is necessary for the clinician to identify the equipment or part of the equipment that requires clinician response or awareness, at least one *visual alarm signal*<sup>53</sup> shall be provided that:
  1. indicates the priority of the highest priority alarm condition; and
  2. can be perceived correctly at a distance of 4 m from the PCA pump.
 (IEC 60601-1-8 2.3.1)
- (2) The *alarm indicator appearance*<sup>54</sup> shall comply with color, flashing frequency, and duty cycle given in Table 5. (IEC 60601-1-8 2.3.1)

Table 5: Alarm Indicator Appearance

Alarm Category	Indicator Color	Flashing Frequency	Duty Cycle
HIGH	Red	1.4 Hz to 2.8 Hz	20% to 80% on
MEDIUM	Yellow	0.4 Hz to 0.8 Hz	20% to 60% on
LOW	Cyan	Constant (on)	100%

- (3) At least one visual alarm signal shall be provided that identifies the specific alarm condition and its priority. This signal shall be perceived correctly (be legible) at a distance of 1 m from the equipment or part of the equipment or from the clinician’s position.<sup>55</sup> (IEC 60601-1-8 2.3.1)
- (4) Visual alarms shall display *alarm symbols*<sup>56</sup> from Table D.201 *Graphical symbols for ALARM SYSTEMS* of standard IEC 60601-1-8. (IEC 60601-1-8 2.3.1)

### 6.4.3 Alarm Audible

- (1) Alarms shall cause *audible alarms signals*<sup>57</sup> that meet the requirements of Tables 203 and 204 of standard IEC 60601-1-8 for alarm pulses, bursts, and harmonics. (IEC 60601-1-8 2.3.1)
- (2) The *auditory volume*<sup>58</sup> of audible alarms signals shall conform to Section 201.3.3.2 *Volume of auditory ALARM SIGNALS and INFORMATION SIGNALS* of standard IEC 60601-1-8. (IEC 60601-1-8 2.3.1)
- (3) The *alarm melody*<sup>59</sup> of audible alarms signals shall conform to Table AAA.1 of standard IEC 60601-1-8 for drug or fluid delivery. “C d g” shall be used for medium priority alarms; “C d g - C d” shall

<sup>53</sup>requirement R6.4.2(1): *visual alarm signal*

<sup>54</sup>requirement R6.4.2(2): *alarm indicator appearance*

<sup>55</sup>requirement R6.4.2(3): *see alarm signal*

<sup>56</sup>requirement R6.4.2(4): *alarm symbols*

<sup>57</sup>requirement R6.4.3(1): *audible alarms signals*

<sup>58</sup>requirement R6.4.3(2): *auditory volume*

<sup>59</sup>requirement R6.4.3(3): *alarm melody*

be used for high priority alarms; “e c” shall be used for warnings and low priority alarms.<sup>60</sup> (IEC 60601-1-8 2.3.1)

- (4) Each tone in the alarm melody shall be composed of a minimum of 4 *harmonic components*<sup>61</sup> in the range 300 Hz to 4000 Hz comprising an inverted 9th jazz chord. (IEC 60601-1-8 2.3.1)

The Control Panel panel, Section 6.5, and the ICE interface 6.7 allows audible alarm inactivation. (UC6 4.1.6)

- (5) Temporarily paused alarms shall reactivate alarm pause duration  $\Delta_{ap} = 10$  minutes after inactivation. (UC6.5 4.1.6)

#### 6.4.4 Alarms Networked

- (1) Alarms shall be issued in order of occurrence.
- (2) If alarms are inactivated or paused through the ICE supervisor user interface, they shall be reactivated upon loss of connection to ICE. (EC 18 4.2.18)

### 6.5 Control Panel

- (1) The *control panel*<sup>62</sup> must display currently-programmed patient data and physician’s prescription. (all UC and EC)
- (2) The PCA pump shall have a *start button*<sup>63</sup>. (UC1.14 §4.1.1 UC7.1 §4.1.7)
- (3) Upon the clinician’s pressing of the start button, *start infusion*<sup>64</sup> prescribed. (UC1.14 §4.1.1 UC7.1 §4.1.7)
- (4) The control panel shall display *helpful messages*<sup>65</sup>. (all UC and EC)
- (5) The PCA pump shall have a *stop button*<sup>66</sup>. (UC1.16 §4.1.1)
- (6) Upon the clinician’s pressing of the stop button, *stop infusion*<sup>67</sup>. (UC1.16 §4.1.1)
- (7) The control panel shall allow *clinician bolus request*<sup>68</sup> and choice of duration. (UC3.1 §4.1.3)
- (8) (removed)
- (9) Prescriptions that violate the soft limits of the drug in the drug library shall issue a visible and audible warning requiring a *soft limit confirmation*<sup>69</sup> by the clinician. (EC2 §4.2.2)

---

<sup>60</sup>The characters c, d, e, g, C refer to relative musical pitches and C is one octave above c.

<sup>61</sup>requirement R6.4.3(4): *harmonic components*

<sup>62</sup>requirement R6.5.0(1): *control panel*

<sup>63</sup>requirement R6.5.0(2): *start button*

<sup>64</sup>requirement R6.5.0(3): *start infusion*

<sup>65</sup>requirement R6.5.0(4): *helpful messages*

<sup>66</sup>requirement R6.5.0(5): *stop button*

<sup>67</sup>requirement R6.5.0(6): *stop infusion*

<sup>68</sup>requirement R6.5.0(7): *clinician bolus request*

<sup>69</sup>requirement R6.5.0(9): *soft limit confirmation*

- (10) Prescriptions that violate a *hard limit*<sup>70</sup> of the drug in the drug library shall be rejected with visible and audible indication when confirmation is attempted by the clinician. (EC3 §4.2.3)
- (11) The Control Panel shall *show alarm*<sup>71</sup> condition as described in Section 6.4.2.<sup>72</sup> (IEC 60601-1-8 2.3.1)
- (12) The Control Panel shall audibly *sound alarm*<sup>73</sup> condition as described in Section 6.4.3.<sup>74</sup> (IEC 60601-1-8 2.3.1)
- (13) Pressing the *stop button silences all alarms* and terminates any alarm signal inactivation.<sup>75</sup> (UC6 §4.1.6)
- (14) The Control Panel shall provide means to *inactivate audible alarms indefinitely*<sup>76</sup>. (UC6 §4.1.6)
- (15) The Control Panel shall provide means to *inactivate audible alarms temporarily*<sup>77</sup> for a predefined period of time. (UC6.5 §4.1.6)
- (16) The Control Panel shall provide means to *cancel alarm signal inactivation*<sup>78</sup>. (UC6.5 §4.1.6)
- (17) When auditory alarms are inactive the control panel shall display an *inactive auditory alarm symbol*<sup>79</sup> from Table D.201 *Graphical symbols for ALARM SYSTEMS* of standard IEC 60601-1-8. (IEC 60601-1-8 2.3.1)
- (18) If the same *alert-stop-start sequence*<sup>80</sup> occurs 3 or more times in ten minutes, infusion will be stopped, and an audible alarm sounded. (EC23 §??)

The Control Panel confirms operation after power-on self-test of

- (19) *sound of audible alarm*<sup>81</sup>, (UC1.2 §4.1.1 EC17 §4.2.17)
- (20) *display of visual information*<sup>82</sup>, and (UC1.2 §4.1.1)
- (21) *tactile response*<sup>83</sup> (button press). (UC1.2 §4.1.1 EC17 §4.2.17)
- (22) The PCA pump shall resume prescribed infusion when the Start button is pressed.<sup>84</sup> (UC7 §4.1.7)
- (23) The PCA pump shall *display infusion rate*<sup>85</sup> currently pumping. (UC1.15 §4.1.1)

---

<sup>70</sup>requirement R6.5.0(10): *hard limit*

<sup>71</sup>requirement R6.5.0(11): *show alarm*

<sup>72</sup>requirement R6.5.0(11): *show alarm*

<sup>73</sup>requirement R6.5.0(12): *sound alarm*

<sup>74</sup>requirement R6.5.0(12): *sound alarm*

<sup>75</sup>requirement R6.5.0(13): *stop silences alarms*

<sup>76</sup>requirement R6.5.0(14): *inactivate audible alarms indefinitely*

<sup>77</sup>requirement R6.5.0(15): *inactivate audible alarms temporarily*

<sup>78</sup>requirement R6.5.0(16): *cancel alarm signal inactivation*

<sup>79</sup>requirement R6.5.0(17): *inactive auditory alarm symbol*

<sup>80</sup>requirement R6.5.0(18): *alert-stop-start sequence*

<sup>81</sup>requirement R6.5.0(19): *sound of audible alarm*

<sup>82</sup>requirement R6.5.0(20): *display of visual information*

<sup>83</sup>requirement R6.5.0(21): *tactile response*

<sup>84</sup>requirement R6.5.0(22): *resume infusion*

<sup>85</sup>requirement R6.5.0(23): *display infusion rate*



## 6.6 Logging

- (1) The PCA pump shall maintain an electronic *event log*<sup>86</sup> to record each action taken by the pump and each event sensed of its environment. (no UC or EC specific to logging)
- (2) The PCA pump shall maintain an electronic *fault log*<sup>87</sup> to record each fault condition, and the associated alarm and/or alert issued.
- (3) Each log entry shall have a *time stamp*<sup>88</sup> with its time of occurrence.
- (4) The patient's prescription shall be retained<sup>89</sup> for at least  $\Delta_{data} = 96$  hours after the PCA pump is turned-off and unplugged.
- (5) Information in event and Fault Logs shall be retained<sup>90</sup> for at least  $\Delta_{log} = 1000$  hours after the PCA pump is turned-off and unplugged.
- (6) The event log shall record 30 days of typical events before overwriting oldest event records first.<sup>91</sup>
- (7) The fault log shall record at least 1000 faults before overwriting oldest fault records first.<sup>92</sup>
- (8) A *real-time clock*<sup>93</sup> must produce timestamps accurate to 10 ms.

## 6.7 ICE Interface

The ICE interface allows the PCA pump to be monitored and controlled remotely, either by a clinician using an ICE supervisor user interface or an ICE app.

- (1) The ICE Interface shall transmit current operating status and infusion rate to the ICE system.<sup>94</sup>
- (2) The ICE interface shall transmit events, alarms, and warnings to the ICE system.<sup>95</sup>
- (3) The ICE interface shall allow a clinician to set the duration of clinician-requested boluses through an ICE supervisor user interface.<sup>96</sup> (UC3.1 §4.1.3)
- (4) The PCA pump shall switch to KVO infusion rate when commanded through its ICE interface.<sup>97</sup> (UC4.4 §4.1.4)
- (5) The PCA pump shall resume prescribed infusion when commanded through its ICE interface.<sup>98</sup> (UC5.5 §4.1.5)

---

<sup>86</sup>requirement R6.6.0(1): *event log*

<sup>87</sup>requirement R6.6.0(2): *fault log*

<sup>88</sup>requirement R6.6.0(3): *time stamp*

<sup>89</sup>requirement R6.6.0(4): *prescription retention*

<sup>90</sup>requirement R6.6.0(5): *log retention*

<sup>91</sup>requirement R6.6.0(6): *event log size*

<sup>92</sup>requirement R6.6.0(7): *fault log size*

<sup>93</sup>requirement R6.6.0(8): *real-time clock*

<sup>94</sup>requirement R6.7.0(1): *ICE operating status*

<sup>95</sup>requirement R6.7.0(2): *ICE alarms*

<sup>96</sup>requirement R6.7.0(3): *ICE bolus duration*

<sup>97</sup>requirement R6.7.0(4): *ICE KVO rate*

<sup>98</sup>requirement R6.7.0(5): *ICE resume infusion*

- (6) When the PCA pump is not connected to an ICE network, or the ICE network connection fails, the PCA pump shall operate as a singular, *stand-alone*<sup>99</sup> device.
- (7) The ICE interface may inactivate alarms.<sup>100</sup> (UC6 4.1.6)

## 6.8 Drug Reservoir

- (1) The *drug reservoir*<sup>101</sup> holds liquid pain-killer supplied by the hospital pharmacy and loaded into the PCA pump by the clinician. (UC1.10 §4.1.1)
- (2) The drug reservoir shall measure its contents.<sup>102</sup> (EC20 §4.2.20 EC21 §4.2.21)
- (3) The measured drug volume shall be within  $V_{rt} = 1$  ml of the actual drug volume.<sup>103</sup>
- (4) All filled prescriptions (liquid, narcotic pain-killer dispensed by the hospital pharmacy) must be labeled at least visibly with<sup>104</sup>
  - a. Patient name
  - b. Drug code
  - c. Name of drug
  - d. Concentration
  - e. Initial volume of drug
  - f. Basal flow rate
  - g. VTBI
  - h. Minimum time between bolus
  - i. Date prescription filled
  - j. Prescribing physician's name
  - k. Pharmacist name

Labels may show additional information. Labels should be difficult to counterfeit or modify without detection, only created and attached to filled prescriptions by a pharmacist in the hospital pharmacy. (UC1.7 §4.1.1)

- (5) Prior to, or coincident with, loading the drug reservoir must also *enter prescription*<sup>105</sup> on the drug container's label using the scanner. (UC1.7 §4.1.1)

---

<sup>99</sup>requirement R6.7.0(6): *stand-alone*

<sup>100</sup>requirement R6.7.0(7): *ICE inactivate alarms*

<sup>101</sup>requirement R6.8.0(1): *drug reservoir*

<sup>102</sup>requirement R6.8.0(2): *reservoir contents*

<sup>103</sup>requirement R6.8.0(3): *reservoir tolerance*

<sup>104</sup>requirement R6.8.0(4): *drug label*

<sup>105</sup>requirement R6.8.0(5): *enter prescription*

- (6) A clinician must personally confirm the prescription<sup>106</sup> is for the patient to be infused. The routine procedures by which clinicians load the drug reservoir must ensure that the prescription filled by the hospital pharmacy is meant for the patient (to be) connected to the PCA pump.<sup>107</sup> (UC1.7 §4.1.1)
- (7) –removed
- (8) The drug loaded into the reservoir must also be found in the PCA pump’s *drug in library*<sup>108</sup>. The drug code of the prescription must match the drug code of a drug library entry. (UC1.9 §4.1.1)
- (9) If the drug volume in the reservoir measures less than  $V_{tra} = 1$  ml, and an infusion is in progress, a *low-reservoir warning*<sup>109</sup> shall be issued. (EC2 §4.2.2)
- (10) If the drug volume in the reservoir measures less than  $V_{ers} = 0.5$  ml, and an infusion is in progress, an *empty-reservoir alarm*<sup>110</sup> shall be issued stopping the pump. (EC3 §4.2.3 )

## 6.9 Drug Library

- (1) The *drug library*<sup>111</sup> can be thought of as a lookup table that, given a drug name and a location, provides typical and safe limits of different infusion parameters. The drug library shall be determined by the hospital pharmacist, and loaded into the PCA pump via its communication port.
- (2) For each drug that may be infused with a PCA pump, the *drug library entry*<sup>112</sup> for that drug shall have data elements listed in Table 6.<sup>113</sup>
- (3) Before commencing infusion, the values of  $VTBI$  and  $F_{basal}$  are checked against the drug library entry of the drug to be infused.<sup>114</sup> (UC1.9 §4.1.1)
- (4) If the drug loaded into the drug reservoir is not present in the drug library, that the drug is unknown is indicated by the user interface, and recorded in the Fault Log. Pump remains stopped.<sup>115</sup> (UC1.9 §4.1.1)

<sup>106</sup>requirement R6.8.0(6): *prescription confirmation*

<sup>107</sup>This involves clinicians checking wristbands with names attached to filled prescriptions by the hospital pharmacy. This is a requirement placed by the PCA pump on its environment so that the pump may safely perform the prescription determined by the physician.

<sup>108</sup>requirement R6.8.0(8): *drug in library*

<sup>109</sup>requirement R6.8.0(9): *low-reservoir warning*

<sup>110</sup>requirement R6.8.0(10): *empty-reservoir alarm*

<sup>111</sup>requirement R6.9.0(1): *drug library*

<sup>112</sup>requirement R6.9.0(2): *drug library entry*

<sup>113</sup>This table of elements of drug library entries removes hard and soft limits upon drug concentration from the drug library entries in “PCA Pump Model.doc”; each different concentration of the same drug dispensed by the hospital pharmacy must have its own entry in the drug library.

<sup>114</sup>requirement R6.9.0(3): *drug library checking*

<sup>115</sup>requirement R6.9.0(4): *unknown drug*

Table 6: Data Elements of a Drug Library Entry

Element Name	Explanation
Drug Code	Unique identifier of the drug and its concentration
Drug Name	Name of the drug
Location	Context of drug application
Dose Rate Unit	The unit of drug dose (for example milliliters/hour)
VTBI Unit	The unit of VTBI (for example milliliter)
Amount	The weight of the drug dissolved in the diluent
Concentration	Drug concentration; as prescribed
VTBI Lower Soft	Lower soft limit of drug volume to be infused
VTBI Lower Hard	Lower hard limit of drug volume to be infused
VTBI Typical	Typical drug volume to be infused
VTBI Upper Soft	Upper soft limit of drug volume to be infused
VTBI Upper Hard	Upper hard limit of drug volume to be infused
Basal Rate Lower Soft	Lower soft limit of basal drug dose rate
Basal Rate Lower Hard	Lower hard limit of basal drug dose rate
Basal Rate Typical	Typical basal drug dose rate
Basal Rate Upper Soft	Upper soft limit of basal drug dose rate
Basal Rate Upper Hard	Upper hard limit of basal drug dose rate
Bolus Typical	Typical Value of Bolus Volume
Bolus Time Typical	Typical duration of clinician commanded bolus

## 6.10 Scanner

The *scanner* reads information from patient wristbands, clinician badges, and drug labels. It may read the information optically or by RFID.

- (1) The scanner shall read and authenticate information from the *patient's wristband*<sup>116</sup>. (UC1.5 UC1.6 §4.1.1)
- (2) The scanner shall read and authenticate information from the *clinician's badge*<sup>117</sup>. (UC1.3 UC1.4 §4.1.1)
- (3) The scanner shall read and authenticate information from the *drug's package label*<sup>118</sup>. (UC1.7 UC1.8 §4.1.1)

<sup>116</sup>requirement R6.10.0(1): *patient's wristband*

<sup>117</sup>requirement R6.10.0(2): *clinician's badge*

<sup>118</sup>requirement R6.10.0(3): *drug's package label*

## 7 Safety Requirements

Because PCA pumps can harm or kill patients, safety is paramount. Although the only safe medical devices are those that are never used, adequate safety can be achieved by a combination of proper use, proper operation, and device features that detect faults and anomalies, changing behavior accordingly.

### 7.1 Safety Architecture

- (1) The PCA pump shall implement a *safety architecture*<sup>119</sup> that separates normal operation from fault detection and response. (reference to Safety Architecture paper)

### 7.2 Anomaly Detection and Response

- (1) When the stop button is pressed, the current pump stroke shall be completed prior to stopping the pump.<sup>120</sup> (FDA ??)
- (2) During normal use and/or single fault condition of the equipment, *continuous reverse delivery*<sup>121</sup> shall not be possible. (IEC 60601-2-24 2.3.1)
- (3) An *air-in-line alarm*<sup>122</sup> shall be triggered by the pump if detectable air bubbles are infused into the patient.<sup>123</sup> (EC12 §4.2.12)
- (4) An *upstream occlusion alarm*<sup>124</sup> shall be triggered when the pump senses an upstream (drug reservoir side) occlusion exceeding  $P_{uo} = 1$  psi. (EC11 §4.2.11)
- (5) A *downstream occlusion alarm*<sup>125</sup> shall be triggered if the pump senses a downstream (patient side) occlusion exceeding  $P_{do} = 10$  psi. (EC10 §4.2.10)
- (6) When an *occlusion alarm*<sup>126</sup> occurs, the pump shall be stopped immediately without completing the current pump stroke.<sup>127</sup> (EC10 §4.2.10 EC11 §4.2.11)
- (7) When an *empty-reservoir alarm*<sup>128</sup> occurs, the current pump stroke shall be completed prior to stopping the pump.<sup>129</sup> (EC21 §4.2.21)
- (8) An *open door alarm*<sup>130</sup> shall be triggered when the reservoir door is opened while the pump is not stopped. (EC23b §4.2.22)

---

<sup>119</sup>requirement R7.1.0(1): *safety architecture*

<sup>120</sup>requirement R7.2.0(1): *complete pump stroke*

<sup>121</sup>requirement R7.2.0(2): *continuous reverse delivery*

<sup>122</sup>requirement R7.2.0(3): *air-in-line alarm*

<sup>123</sup>Detecting the smallest-possible air bubble is a goal, not a requirement.

<sup>124</sup>requirement R7.2.0(4): *upstream occlusion alarm*

<sup>125</sup>requirement R7.2.0(5): *downstream occlusion alarm*

<sup>126</sup>requirement R7.2.0(6): *occlusion alarm*

<sup>127</sup>If the mechanical pump chosen has a pump stroke.

<sup>128</sup>requirement R7.2.0(7): *empty-reservoir alarm*

<sup>129</sup>If the mechanical pump chosen has a pump stroke.

<sup>130</sup>requirement R7.2.0(8): *open door alarm*

### 7.3 Power Supply

Many crucial medical devices continue to operate on battery backup when mains electricity supply fails.

- (1) The PCA pump shall continue to infuse for 10 minutes during interruption of mains electricity supply using *battery backup*<sup>131</sup>, either continuously or spread over an hour. (Five minutes to recharge per minute using battery.)
- (2) The user interface must show that the PCA pump is working on battery backup, and an estimate of the number of minutes of battery-powered infusion remain.<sup>132</sup>
- (3) The estimate of remaining battery energy must be accurate to within  $X_{bttty} = 25\%$ .<sup>133</sup>
- (4) If the estimated battery life remaining is less than  $\Delta_{lba} = 3$  minutes, the pump shall issue a *low-battery warning*<sup>134</sup>.
- (5) The PCA pump shall detect battery failure and issue a *battery failure alarm*<sup>135</sup>.
- (6) The PCA pump shall detect power supply voltage out-of-range, issue a *voltage out-of-range warning*<sup>136</sup>, and switch to battery backup when out-of-range.
- (7) The PCA pump must not leak current greater than 10 mA.<sup>137</sup>
- (8) Component failure must not harm patient (beyond stopping function).<sup>138</sup>
- (9) The PCA pump must be *electromagnetically compatible*<sup>139</sup> according to IEC 60601-1-2 (2001) *Medical Electrical Equipment, Part 1: General Requirements for Safety, 2. Collateral Standard: Electromagnetic Compatibility - Requirements and Tests*. (IEC 60601-1-2 2.3.1)
- (10) The PCA pump must withstand *electrostatic discharge*<sup>140</sup>.
- (11) The PCA pump must *filter power interference*<sup>141</sup> from mains.

### 7.4 Diagnostics and Fail-Stop

Correct operation depends on system (hardware) integrity. Typically this is assured by power-on-self-tests, periodic self-tests, and continuous fault-detection and masking. These requirements demand *assurance*; how that assurance is achieved is left up to the designer.

---

<sup>131</sup>requirement R7.3.0(1): *battery backup*

<sup>132</sup>requirement R7.3.0(2): *remaining battery minutes*

<sup>133</sup>requirement R7.3.0(3): *remaining battery accuracy*

<sup>134</sup>requirement R7.3.0(4): *low-battery warning*

<sup>135</sup>requirement R7.3.0(5): *battery failure alarm*

<sup>136</sup>requirement R7.3.0(6): *voltage out-of-range warning*

<sup>137</sup>requirement R7.3.0(7): *leakage current*

<sup>138</sup>requirement R7.3.0(8): *component failure*

<sup>139</sup>requirement R7.3.0(9): *electromagnetically compatible*

<sup>140</sup>requirement R7.3.0(10): *electrostatic discharge*

<sup>141</sup>requirement R7.3.0(11): *filter power interference*

- (1) The PCA pump shall perform a *power-on self-test*<sup>142</sup> (POST) to assure system integrity after being turned on, yet before any infusion begins. Failure of POST shall raise a *POST alarm*, stop pump, record it in the Fault Log, and display the reason for failure on the user interface. (EC4 §4.2.4)
- (2) The PCA pump shall perform *periodic self-tests*<sup>143</sup> to assure system integrity during long periods of use. Failure of a self-test shall raise a *self-test alarm*, stop pump, record it in the Fault Log, and display the reason for failure on the user interface. (EC22c §4.2.22)
- (3) The PCA pump shall have *continuous fault-detection*<sup>144</sup> and masking. Hardware monitors of thread heartbeat, memory error correction codes are examples. (EC22d §4.2.22)
- (4) Occurrence of unavoidable *single-event upsets*<sup>145</sup> caused by cosmic-ray-induced high- and thermal-energy neutrons must be either masked, or detected to fail-stop. (EC22d §4.2.22)
- (5) Successfully *masked faults*<sup>146</sup> shall be recorded in the Fault Log, but not raise an alarm. (EC22e §4.2.22)
- (6) All unmasked *hardware detected faults*<sup>147</sup> shall raise a fault alarm, stop pump, record it in the Fault Log, and display the reason for fault on the user interface. (EC22 §4.2.22)
- (7) Hardware faults that prevent operation of the Control Panel shall illuminate a *hardware fault indicator*<sup>148</sup> (light-emitting diode). (EC22f §4.2.22)

## 7.5 Tamper-Resistant Door

- (1) Because the drugs used for analgesia are often narcotic, requiring Drug Enforcement Agency (DEA) tracking if used in the United States, the drug reservoir and means to change prescriptions during infusion must be inhibited with a locked, *tamper-resistant door*<sup>149</sup>.
- (2) Before infusion, the door must be closed and locked.<sup>150</sup> (UC1.10 §4.1.1)
- (3) Hospital procedures must endow the attending clinician access to the *door key*<sup>151</sup>, yet prevent other persons' access. Key-handling processes are beyond the scope of these requirements, but much depends on the attending clinician: it's the right drug, in the right patient, with the right prescription from a physician authorized to prescribe narcotics for those suffering great pain.
- (4) The PCA *pump case*<sup>152</sup> must be at least difficult to breach as its tamper-resistant door. Breaking the case shall not be easier to access the drug reservoir than breaching the door.

---

<sup>142</sup>requirement R7.4.0(1): *power-on self-test*

<sup>143</sup>requirement R7.4.0(2): *periodic self-tests*

<sup>144</sup>requirement R7.4.0(3): *continuous fault-detection*

<sup>145</sup>requirement R7.4.0(4): *single-event upsets*

<sup>146</sup>requirement R7.4.0(5): *masked faults*

<sup>147</sup>requirement R7.4.0(6): *hardware detected faults*

<sup>148</sup>requirement R7.4.0(7): *hardware fault indicator*

<sup>149</sup>requirement R7.5.0(1): *tamper-resistant door*

<sup>150</sup>requirement R7.5.0(2): *door closed and locked*

<sup>151</sup>requirement R7.5.0(3): *door key*

<sup>152</sup>requirement R7.5.0(4): *pump case*

## 7.6 Biocompatibility

- (1) All materials that contact fluid shall be *biocompatible*<sup>153</sup>.
- (2) The PCA pump shall be *cleaned and disinfected*<sup>154</sup> after use.

## 7.7 Mechanical

- (1) The PCA pump shall *minimize drug leakage*<sup>155</sup>.

---

<sup>153</sup>requirement R7.6.0(1): *biocompatible*

<sup>154</sup>requirement R7.6.0(2): *cleaned and disinfected*

<sup>155</sup>requirement R7.7.0(1): *minimize drug leakage*



## 8 Security

The PCA pump uses security processes, sparingly, to minimize erroneous usage and control access to patient information. These security processes include encryption (for confidentiality), hashing (for authentication), key generation, and key repository.

### 8.1 Authentication

- (1) Clinicians authorization to operate the PCA pump must be authenticated.<sup>156</sup> (UC1.4 §4.1.1)
- (2) Patient's identity and admittance to the hospital must be authenticated.<sup>157</sup> (UC1.6 §4.1.1)
- (3) Drug container must have a valid prescription for the particular patient to be infused by the PCA pump.<sup>158</sup> (UC1.8 §4.1.1)
- (4) Drug library information shall be authenticated before it is accepted.<sup>159</sup>

### 8.2 Confidentiality

- (1) Patient information must be restricted to those providing care for the patient, and the patient.<sup>160</sup>

### 8.3 Provisioning

- (1) Provisioning of initial security keys which form a root of trust must require physical connection to a jack distinct from normal operation.<sup>161</sup>
- (2) The provisioning jack must be physically inaccessible, except to authorized technical personnel.<sup>162</sup> Jacks for test equipment must be similarly inaccessible.
- (3) Provisioning (or re-provisioning) shall not be possible through an ICE network.<sup>163</sup>
- (4) Provisioning shall be a single, unitary block-transfer.<sup>164</sup>

Each of the requirements in preceding sections, must be allocated to an architectural component in section 10 or labeling in section 9, following.

---

<sup>156</sup>requirement R8.1.0(1): *clinician authentication*

<sup>157</sup>requirement R8.1.0(2): *patient authentication*

<sup>158</sup>requirement R8.1.0(3): *prescription authentication*

<sup>159</sup>requirement R8.1.0(4): *drug library authentication*

<sup>160</sup>requirement R8.2.0(1): *confidentiality*

<sup>161</sup>requirement R8.3.0(1): *provisioning jack*

<sup>162</sup>requirement R8.3.0(2): *protected jack*

<sup>163</sup>requirement R8.3.0(3): *provisioning channel disjointness*

<sup>164</sup>requirement R8.3.0(4): *provisioning unitarily*

**Part III**

**Labeling and Architecture**

## 9 Labeling of Nonfunctional Requirements

Some system requirements (environmental or nonfunctional) are properly allocated to medical device *labeling*.<sup>165</sup>

Requirements for temperature range, atmospheric pressure, humidity, and splashing must be met by the user as listed in device labeling. Drug containers must be labeled with patient name, drug code, name of drug, concentration, initial volume in container, prescribed basal flow rate, VTBI, minimum time between bolus, date of filling, prescribing physician, and pharmacist's name.

Clinicians using the device must be trained; only trained clinicians may be authenticated.

### *Allocated Requirements*

R2.4.0(1) temperature range

R2.4.0(2) atmospheric pressure

R2.4.0(3) relative humidity

R2.4.0(4) splashing

R5.8.0(4) drug label

R6.6.0(2) cleaned and disinfected

Non-functional electrical requirements that must be upheld by the design.

### *Allocated Requirements*

R6.3.0(7) leakage current

R6.3.0(8) component failure

R6.3.0(9) electromagnetically compatible

R6.3.0(10) electrostatic discharge

R6.3.0(11) filter power interference

---

<sup>165</sup>Labeling is a term-of-art for FDA encompassing not just what written on the product itself, but its packaging, user manuals, and even advertisements and presentations made by sales staff. Fobbing-off requirements onto labeling should be shunned.

## 10 Functional Architecture

The context for using the PCA pump is depicted in Figure 23. A *patient* receives infused drug, and requests more by pushing the button. A *nurse* (a.k.a. clinician) sees, hears, and touches the control panel on the PCA pump. The PCA pump is connected to the ICE network, along with other medical devices. The PCA pump interacts with software (a.k.a. app) running on the ICE supervisor processor that controls the ICE network. The app may coordinate the operation of the PCA pumps with other medical devices. The app also displays information and on a console at a nurses station, and transmits commands from the console to the PCA pump. A technician may connect a cable to a protected maintenance jack, through which logs can be queried, drug library may be installed, and security can be provisioned.

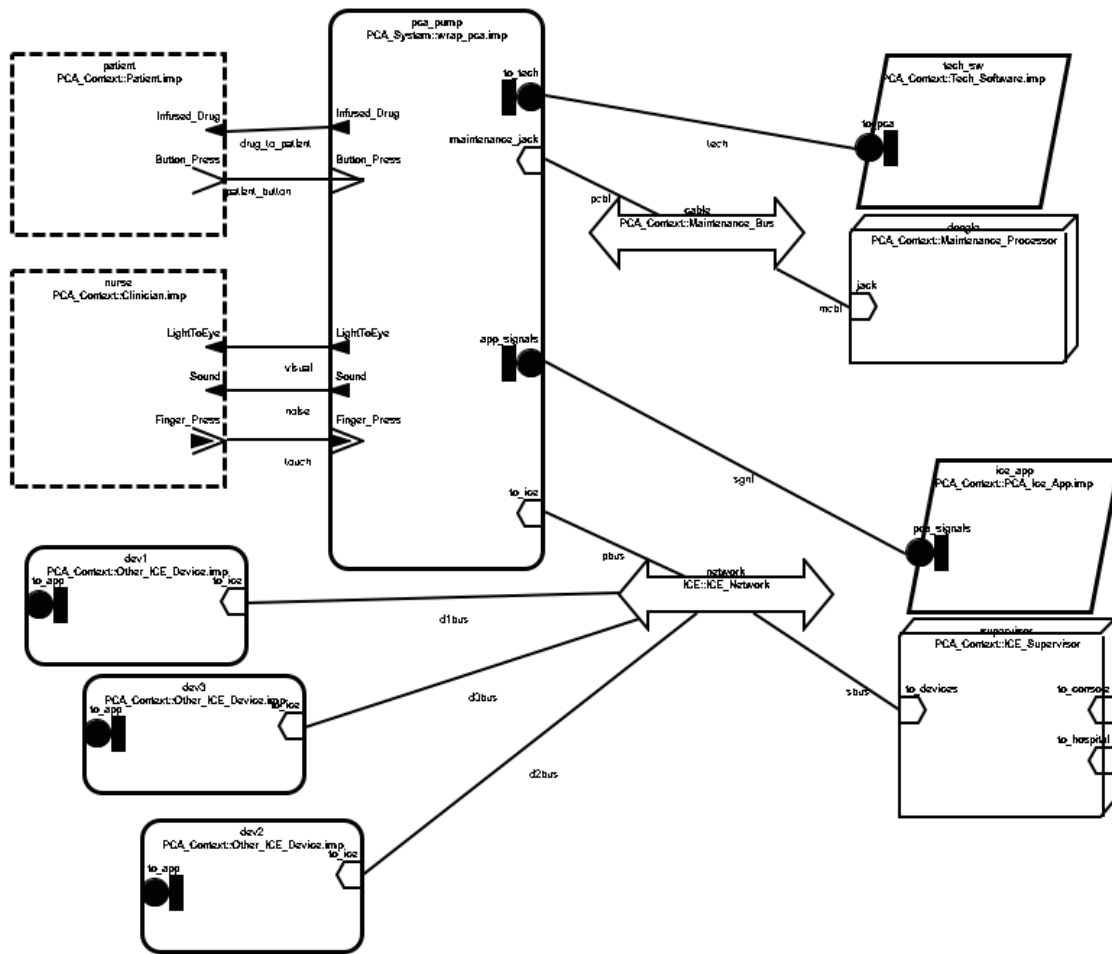

Figure 23: PCA Pump Context

The PCA Pump *functional architecture* partitions system operation into smaller, simpler pieces,

recursively. The PCA Pump’s top-level functional architecture is shown in Figure 24. The behaviors of each component are summarized in Table 7.

The *ICE Bus Adaptor* translates the events and data from the five feature groups comprising the ICE Interface into transactions on the ICE Bus<sup>166</sup>. The function of the ICE Bus Adaptor is defined in section 10.1.

The *Maintenance Processor* allows a technician to read the logs, or load the drug library through a connector behind the drug reservoir door. The function of the Maintenance Processor is defined in section 10.2.

The *PCA component* performs the actual pump operation. The PCA component is partitioned into the functional components in Table 8, depicted in Figure 25, and defined in section 10.3.

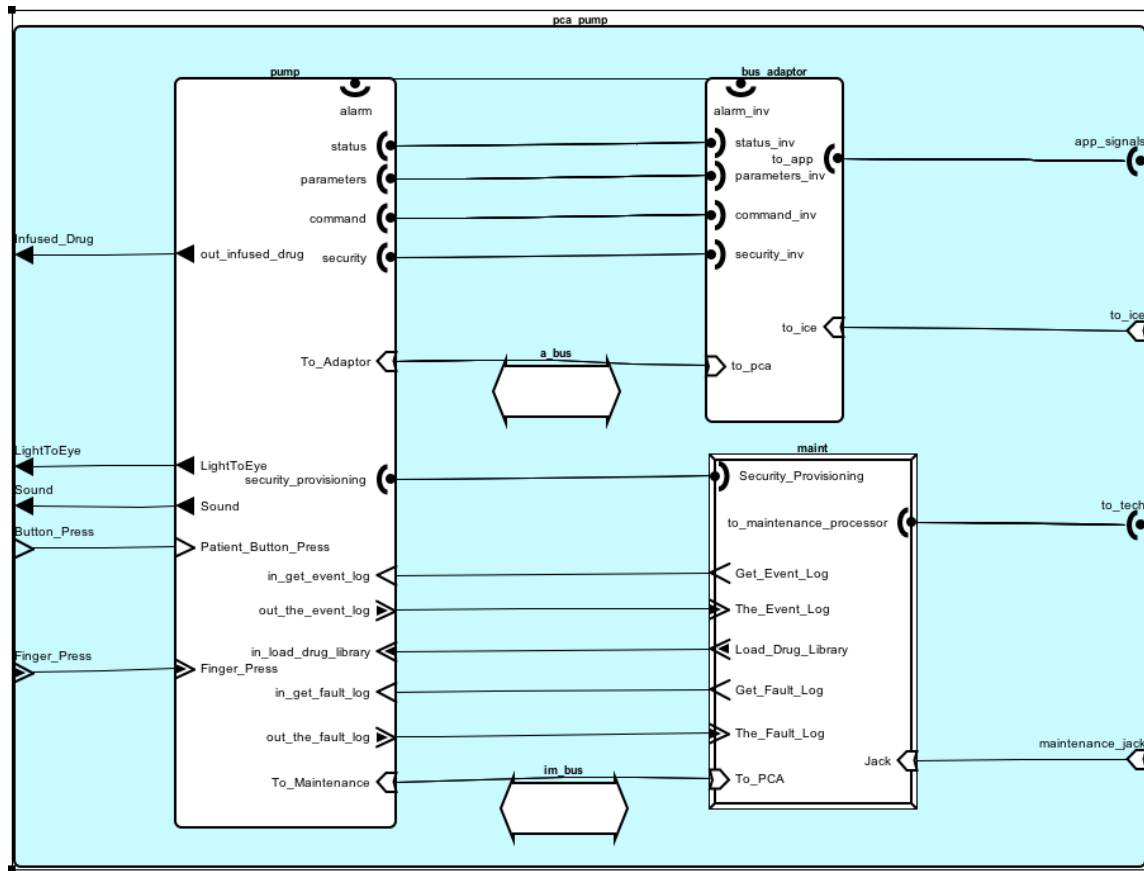

Figure 24: PCA Pump Functional Architecture Top-Level

<sup>166</sup>ASTM-F2761 uses the term ICE “Network”

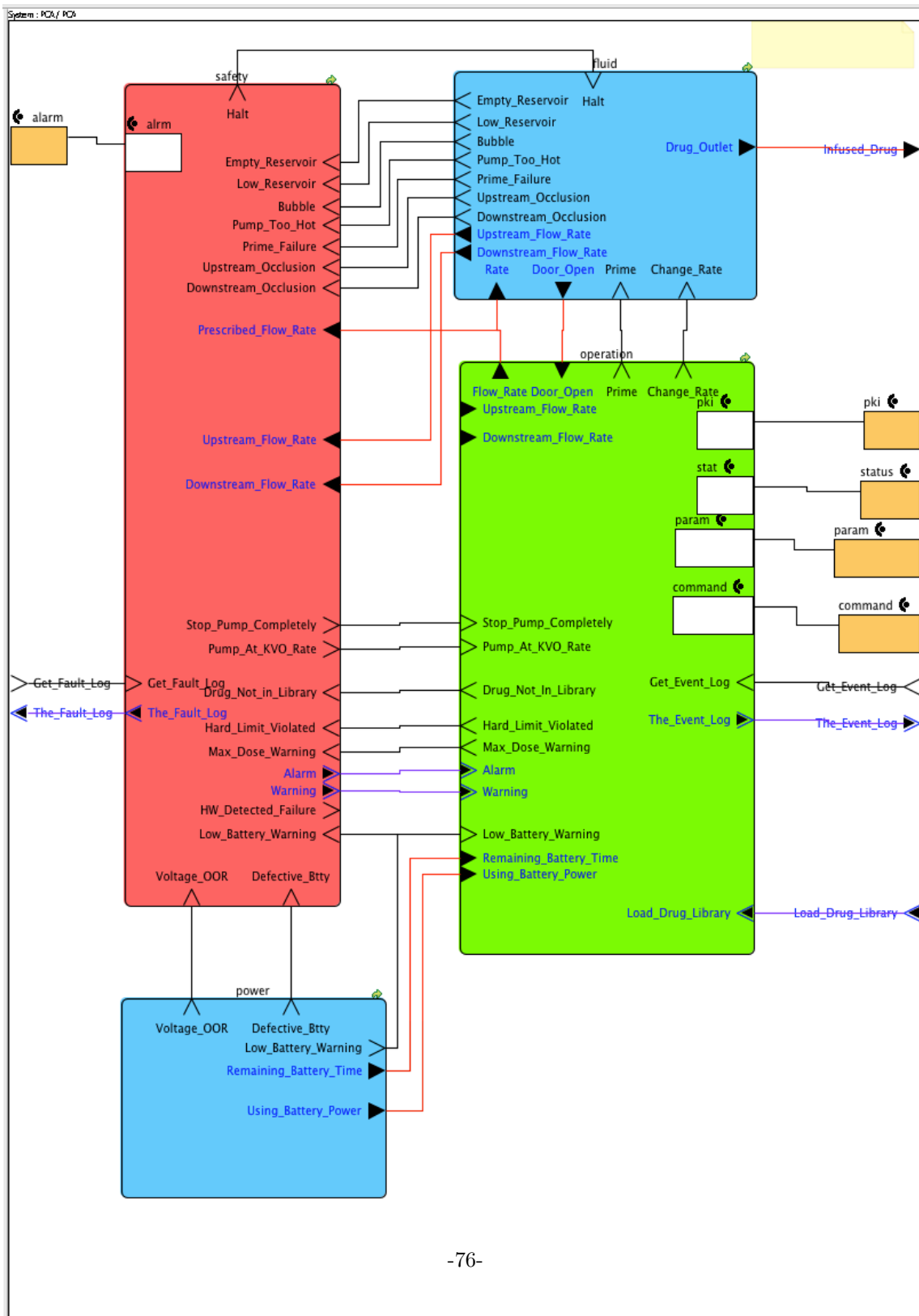

Figure 25: PCA Functional Components

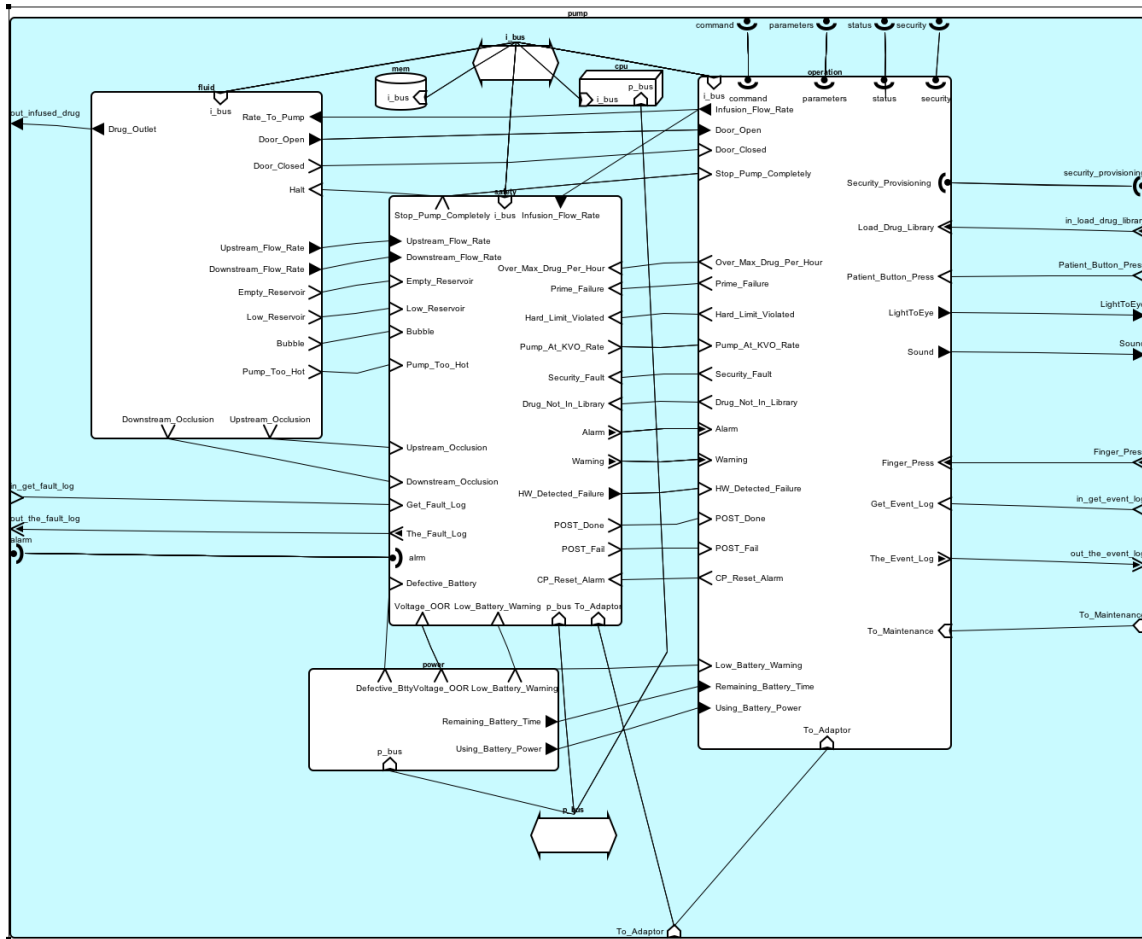

Figure 26: PCA Functional Components

Table 7: Top-Level Components

Component	Behavior
ICE Bus Adaptor	translates events and data into bus transactions
PCA	performs pump operation
Maintenance	technician access to logs, drug library

Table 8: Functional Components

Component	Behavior
fluid	holds and moves drug
operation	controls pump operation
safety	checks for faults; inhibits possibly hazardous infusion; signals alarms and warnings
power	coordinates battery and power supply; detects power anomalies

## 10.1 ICE Bus Adaptor

An *ICE interface* provides a standard<sup>167</sup> yet flexible way for ICE devices to communicate with the ICE system which may include ICE apps in addition to a supervisor user interface which allows a clinician, usually a nurse, to monitor and control all ICE devices used in a unit.

An ICE interface has five parts: commands, parameters, security status, and alarms. The standard ICE interface is defined using AADL prototype feature groups which may be extended by particular ICE devices to include signals particular to those devices. These feature groups are depicted in Figures 24 and 25 as colored, rectangles.

The *ICE Bus Adaptor* converts data and events on an ICE interface, into transactions on an ICE bus.

### *Allocated Requirements*

- R5.4.0(1) issue alarms and warnings
- R5.7.0(1) ICE operating status
- R5.7.0(2) ICE alarms
- R5.7.0(3) ICE bolus duration
- R5.7.0(4) ICE KVO rate
- R5.7.0(5) ICE resume infusion
- R7.3.0(3) provisioning channel disjointness

## 10.2 Maintenance Processor

The *maintenance processor* provides a test interface and security provisioning channel.

---

<sup>167</sup>A formal standard for ICE interfaces has not been determined, but will implement the intent of ASTM F2761-09 Subclause 4.4 ICE Equipment Interface.



*Allocated Requirements*

R7.3.0(1) provisioning jack R7.3.0(2) protected jack

**10.3 PCA Component****10.4 Power Subsystem**

The *power subsystem* consists of a battery, power control, and an implicit power supply as depicted in Figure 27.

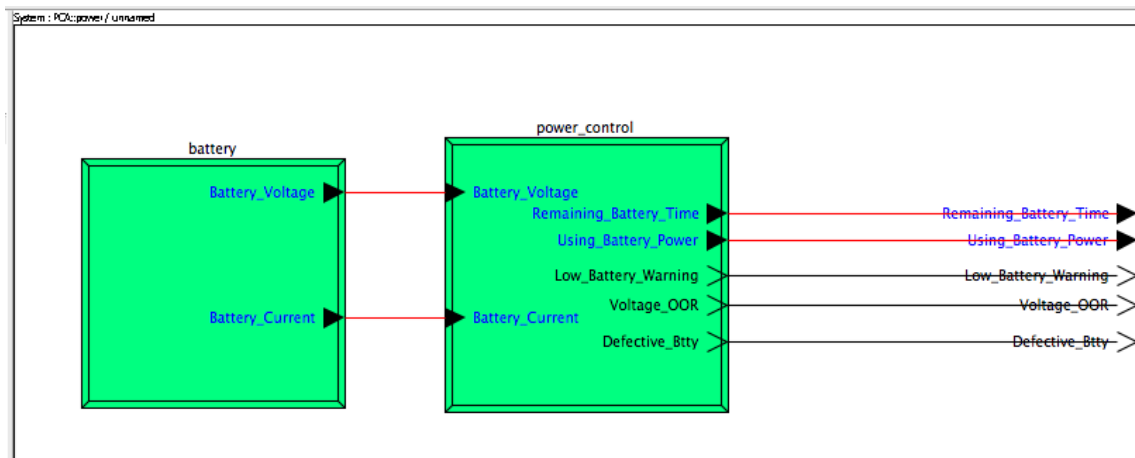

Figure 27: Power Subsystem

**10.4.1 Power Supply**

The *power supply* converts alternating current energy into direct current that powers the electronic components.

*Allocated Requirements*

R6.3.0(6) voltage out-of-range warning

**10.4.2 Battery**

The *battery* provides reserve energy to operate the PCA pump when mains power fails.

*Allocated Requirements*

R6.3.0(1) battery backup

### 10.4.3 Power Control

The *power control* switches between battery-backup and mains supply, and detects anomalies like voltage out-of-range.

#### *Allocated Requirements*

- R5.4.1(3) power and battery failure
- R6.3.0(2) remaining battery minutes
- R6.3.0(3) remaining battery accuracy
- R6.3.0(4) low-battery warning
- R6.3.0(5) battery failure alarm
- R6.3.0(6) voltage out-of-range warning

## 10.5 Operation Subsystem

The *operation subsystem*, depicted in Figure 28, controls infusion, performs security operations, and operates the user interface. It also includes a scanner and patient button. The behaviors of each operation component are summarized in Table 9.

Table 9: Operation Components

Component	Behavior
control_panel	displays information sounds and displays alarms and warnings senses finger touch for pump control
operation_process	holds thread which controls operation
security	performs privacy and authentication
patient_button	patient request bolus
scanner	reads patient wristband, clinician badge, and drug label

### 10.5.1 Control Panel

The *control panel* combines a touch panel with a speaker by which a clinician can enter and confirm configuration and see and hear alarms and warnings.

It

- is used by the clinician to start and stop infusion.<sup>168</sup>
- displays the prescription read from the drug container by the scanner for confirmation or rejection.
- displays the PCA pump's status.
- allows request of a bolus by a clinician.

<sup>168</sup>Is a separate priming operation needed before the needle is inserted and infusion is started?

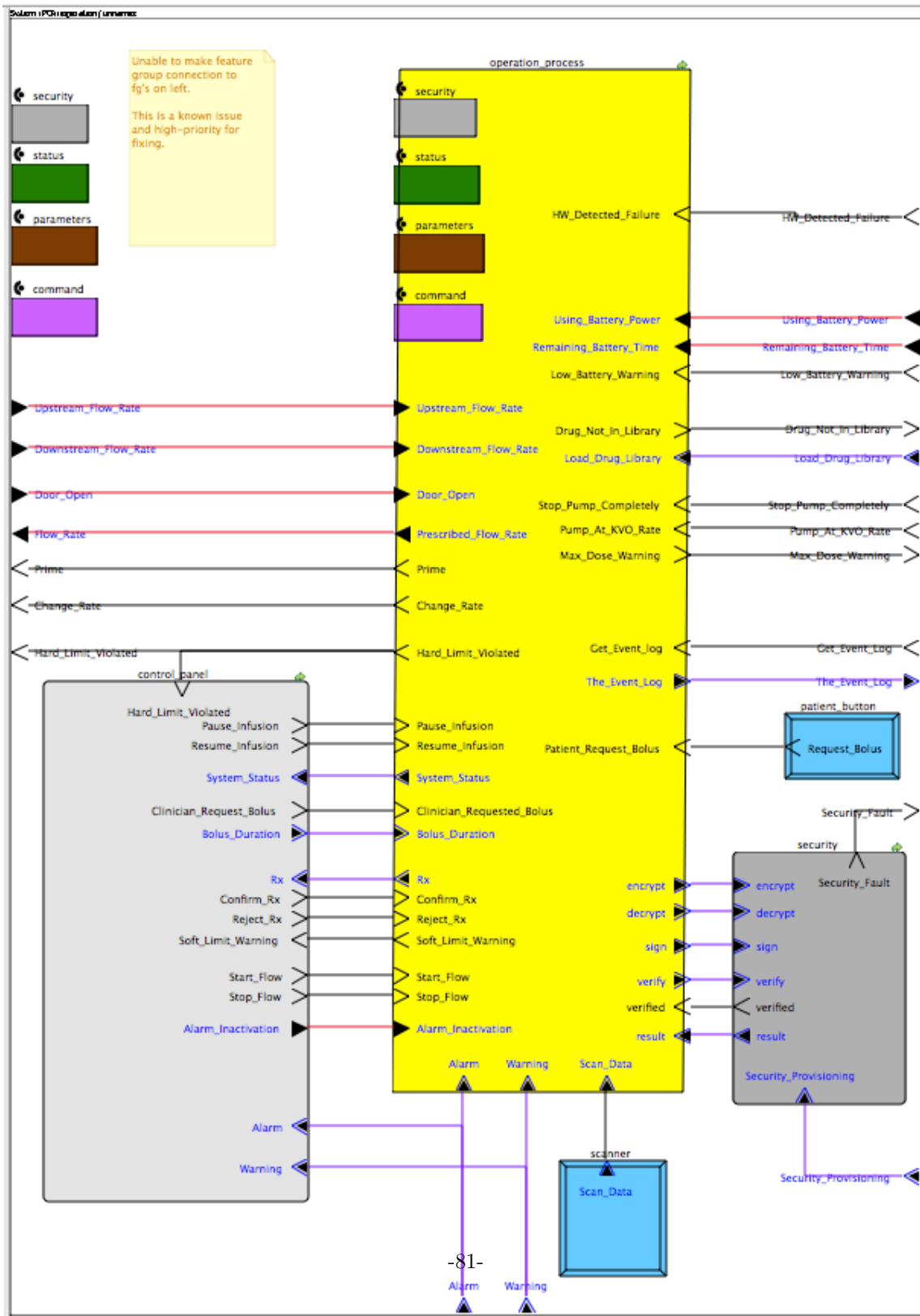

Figure 28: Operation Subsystem

- allows entry of the clinician requested bolus duration.
- displays alarm and warning indications
- sounds alerts for alarm and warning indications
- allows alarm inactivation
- displays if and how alarms are currently inactivated

#### *Allocated Requirements*

R5.4.0(1) issue alarms and warnings  
 R5.4.2(1) visual alarm signal  
 R5.4.2(2) alarm indicator appearance  
 R5.4.2(3) see alarm signal  
 R5.4.2(4) alarm symbols  
 R5.4.3(1) audible alarms signals  
 R5.4.3(2) auditory volume  
 R5.4.3(3) alarm melody  
 R5.4.3(4) harmonic components  
 R5.5.0(1) control panel  
 R5.5.0(2) start button  
 R5.5.0(5) stop button  
 R5.5.0(7) clinician bolus request  
 R5.5.0(8) prescription confirmation  
 R5.5.0(9) soft limit confirmation  
 R5.5.0(11) show alarm  
 R5.5.0(12) sound alarm  
 R5.5.0(13) stop silences alarms  
 R5.5.0(14) inactivate audible alarms indefinitely  
 R5.5.0(15) inactivate audible alarms temporarily  
 R5.5.0(16) cancel alarm signal inactivation  
 R5.5.0(17) inactive auditory alarm symbol  
 R5.5.0(18) alert-stop-start sequence  
 R5.5.0(19) sound of audible alarm  
 R5.5.0(20) display of visual information  
 R5.5.0(21) tactile response  
 R5.5.0(22) resume infusion  
 R5.5.0(23) display infusion rate  
 R5.8.0(6) prescription confirmation  
 R5.9.0(5) hard limit  
 R5.9.0(6) soft limit

### **10.5.2 Operation Process**

The *operation process* contains threads for operation, drug library, and event logging as depicted in Figure 29.

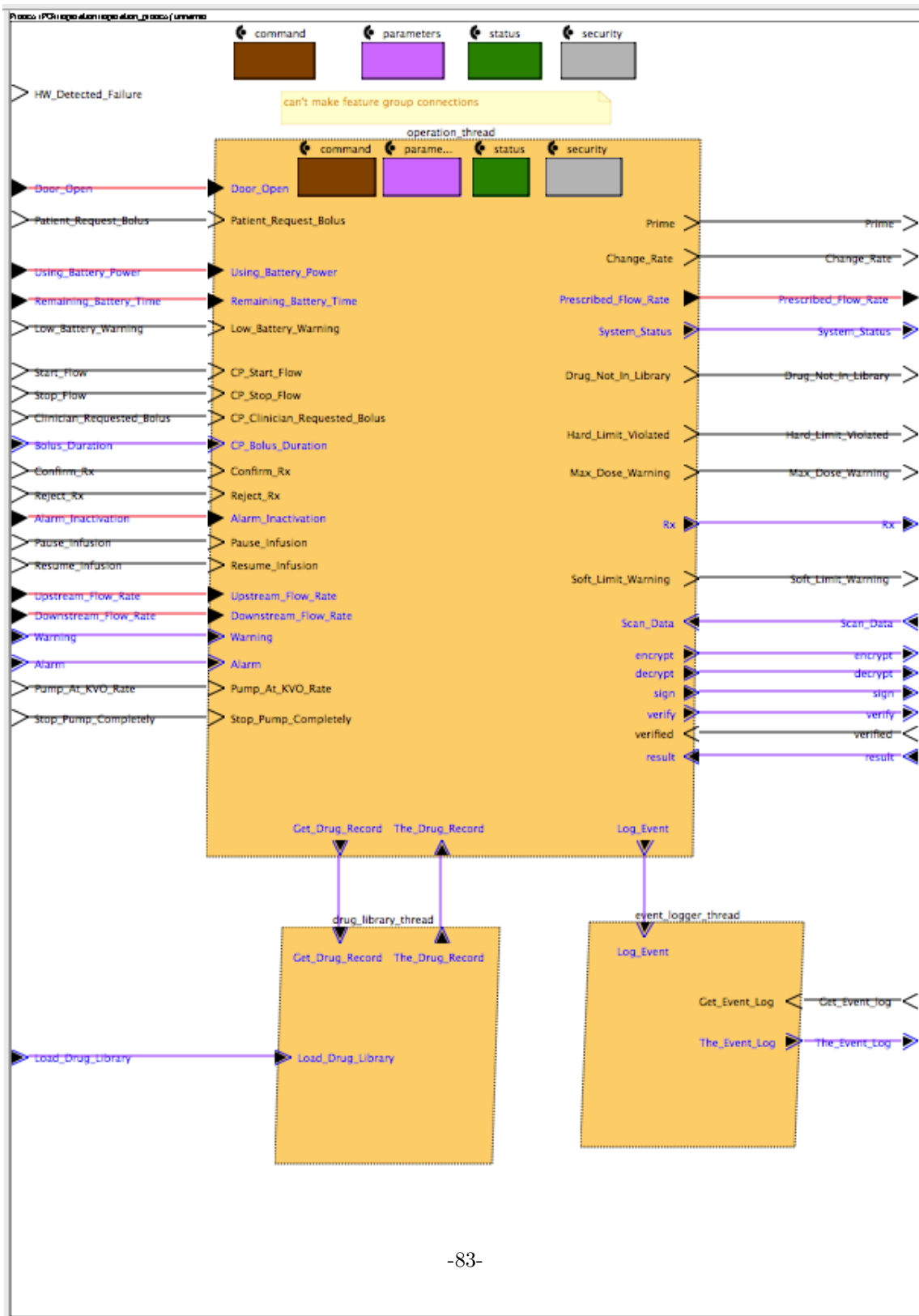

Figure 29: Operation Process

### 10.5.3 Boss Thread

The *boss thread* coordinates and controls the other threads.

### 10.5.4 Rate Controller Thread

The *rate controller thread* determines the pump rate.

#### *Allocated Requirements*

- R4.1.0(1) basal flow rate
- R4.1.0(5) minimum KVO flow rate
- R4.2.0(2) patient-requested bolus
- R4.1.0(4) alarm stops basal rate
- R4.2.0(6) alarm stops patient-requested bolus
- R4.3.0(2) clinician-requested bolus
- R4.3.0(3) patient-requested bolus takes precedence
- R4.3.0(4) alarm halts clinician-requested bolus
- R4.3.0(7) max dose warning
- R5.2.0(2) halt pumping
- R5.5.0(3) start infusion
- R5.5.0(6) stop infusion
- R6.5.0(2) door closed and locked

### 10.5.5 Prescription Checker Thread

The *prescription checker thread* checks hard and soft limits.

#### *Allocated Requirements*

- R4.2.0(4) maximum VTBI
- R4.3.0(5) maximum clinician-chosen duration
- R4.3.0(6) minimum clinician-chosen duration
- R5.3.0(1) device parameters
- R5.5.0(10) hard limit
- R5.5.0(8) prescription confirmation
- R5.5.0(9) soft limit confirmation
- R5.6.0(4) prescription retention
- R5.8.0(6) prescription confirmation
- R5.9.0(5) hard limit
- R5.9.0(6) soft limit

### 10.5.6 ICE Thread

The *ICE thread* sends and receives signals through the ice bus adaptor.

#### *Allocated Requirements*

- R5.7.0(1) ICE operating status

- R5.7.0(2) ICE alarms
- R5.7.0(3) ICE bolus duration
- R5.7.0(4) ICE KVO rate
- R5.7.0(5) ICE resume infusion
- R5.7.0(6) stand-alone
- R5.7.0(7) ICE inactivate alarms

### 10.5.7 Security Thread

The *security thread* authenticates.

#### *Allocated Requirements*

- R7.1.0(1) clinician authentication
- R7.1.0(2) patient authentication
- R7.1.0(3) prescription authentication
- R7.1.0(4) drug library authentication

### 10.5.8 Max Drug Per Hour Thread

The *max drug per hour thread* keeps track of how much drug has been infused within the previous hour.

#### *Allocated Requirements*

- R4.2.0(5) max dose warning

### 10.5.9 Patient Bolus Checker

The *patient bolus checker* thread prevents patient-requests bolus delivery sooner than the minimum time between patient-requested bolus.

#### *Allocated Requirements*

- R4.2.0(3) minimum time between patient-requested bolus

### 10.5.10 Drug Library Thread

The *drug library thread* stores the drug library provided by the hospital pharmacy, and retrieves the drug record corresponding to the drug loaded into the reservoir.

#### *Allocated Requirements*

- R5.8.0(8) drug in library
- R5.9.0(1) drug library
- R5.9.0(2) drug library entry
- R5.9.0(3) drug library checking
- R5.9.0(4) unknown drug

### 10.5.11 Event Logger Thread

The *event logger thread* records all actions or events for later review or audit.

#### *Allocated Requirements*

- R5.6.0(1) event log
- R5.6.0(3) time stamp
- R5.6.0(5) log retention
- R5.6.0(6) event log size

### 10.5.12 Patient Button

The *patient button* allows the patient to request an extra bolus of drug on demand. It may be connected by wire or RF to the PCA pump so that it is conveniently located for the patient.

#### *Allocated Requirements*

- R4.2.0(2) patient-requested bolus

### 10.5.13 Scanner

The *scanner* reads an optical or RFID code on the patient, clinician, and the drug container that is loaded into the reservoir.

#### *Allocated Requirements*

- R4.1.0(1) basal flow rate
- R5.3.0(1) device parameters
- R5.8.0(5) enter prescription
- R5.10.0(1) patient's wristband
- R5.10.0(2) clinician's badge
- R5.10.0(3) drug's package label

## 10.6 Security Subsystem

The *security subsystem*, depicted in Figure 30 performs authentication calculations of patient wrist bands, clinician badges, prescription labels, drug libraries, and messages with ICE. It will also encrypt patient data to be sent to an electronic health record system. Within the security subsystem, a crypto process holds a crypto thread which controls a trusted platform module (TPM). A personal presence button must be pressed by a person for certain TPM initializations.<sup>169</sup>

#### *Allocated Requirements*

- R7.1.0(1) clinician authentication
- R7.1.0(2) patient authentication
- R7.1.0(3) prescription authentication
- R7.1.0(4) drug library authentication

---

<sup>169</sup>Provisioning?



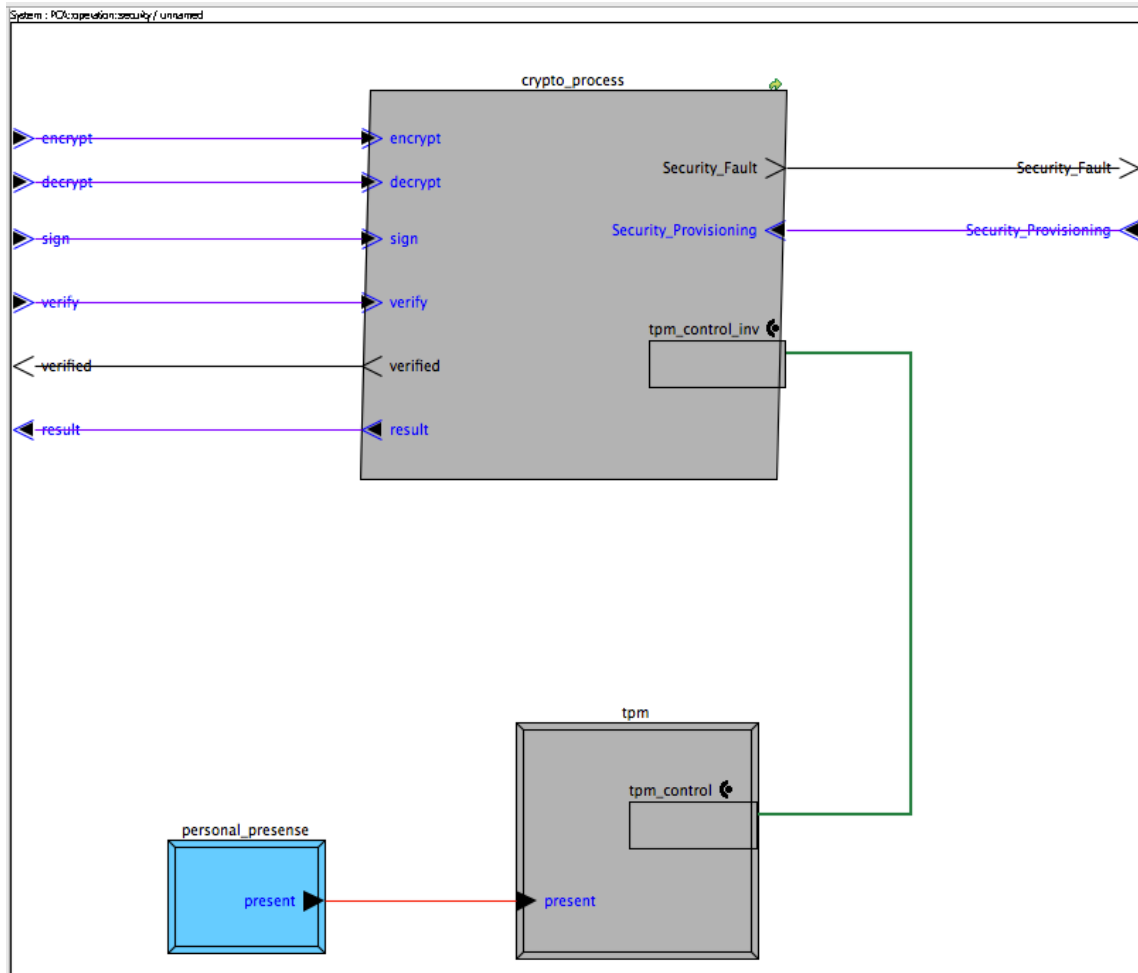

Figure 30: Security Subsystem

R7.2.0(1) confidentiality  
R7.3.0(3) provisioning channel disjointness  
R7.3.0(4) provisioning unitarily

## 10.7 Fluid Subsystem

The *fluid subsystem* moves drug from the reservoir to the line to the patient and is depicted in Figure 31. The drug flows from the reservoir, through the upstream monitor to the pump, then through the downstream monitor to the tube to the patient.

### *Allocated Requirements*

R6.6.0(1) biocompatible

### 10.7.1 Pump

The *pump* moves fluid at specified rate, primes itself, announces if priming fails, indicates when it's too hot, and halts pumping when commanded.

### *Allocated Requirements*

R4.1.0(2) basal infusion flow range  
R4.1.0(3) basal infusion flow tolerance  
R5.2.0(1) pump drug  
R5.2.0(2) halt pumping  
R5.4.0(8) pump overheated alarm  
R6.2.0(1) complete pump stroke  
R6.2.0(2) continuous reverse delivery  
R6.2.0(6) occlusion alarm  
R5.2.0(3) reverse flow

### 10.7.2 Upstream Monitor

The *upstream monitor* measures drug flow into the pump and detects upstream occlusion.

### *Allocated Requirements*

R5.1.0(1) measure drug flow  
R5.1.0(3) detect upstream occlusion

### 10.7.3 Downstream Monitor

The *downstream monitor* measures drug flow out of the pump and detects downstream occlusion, and air-in-line embolism.

### *Allocated Requirements*

R5.1.0(1) measure drug flow

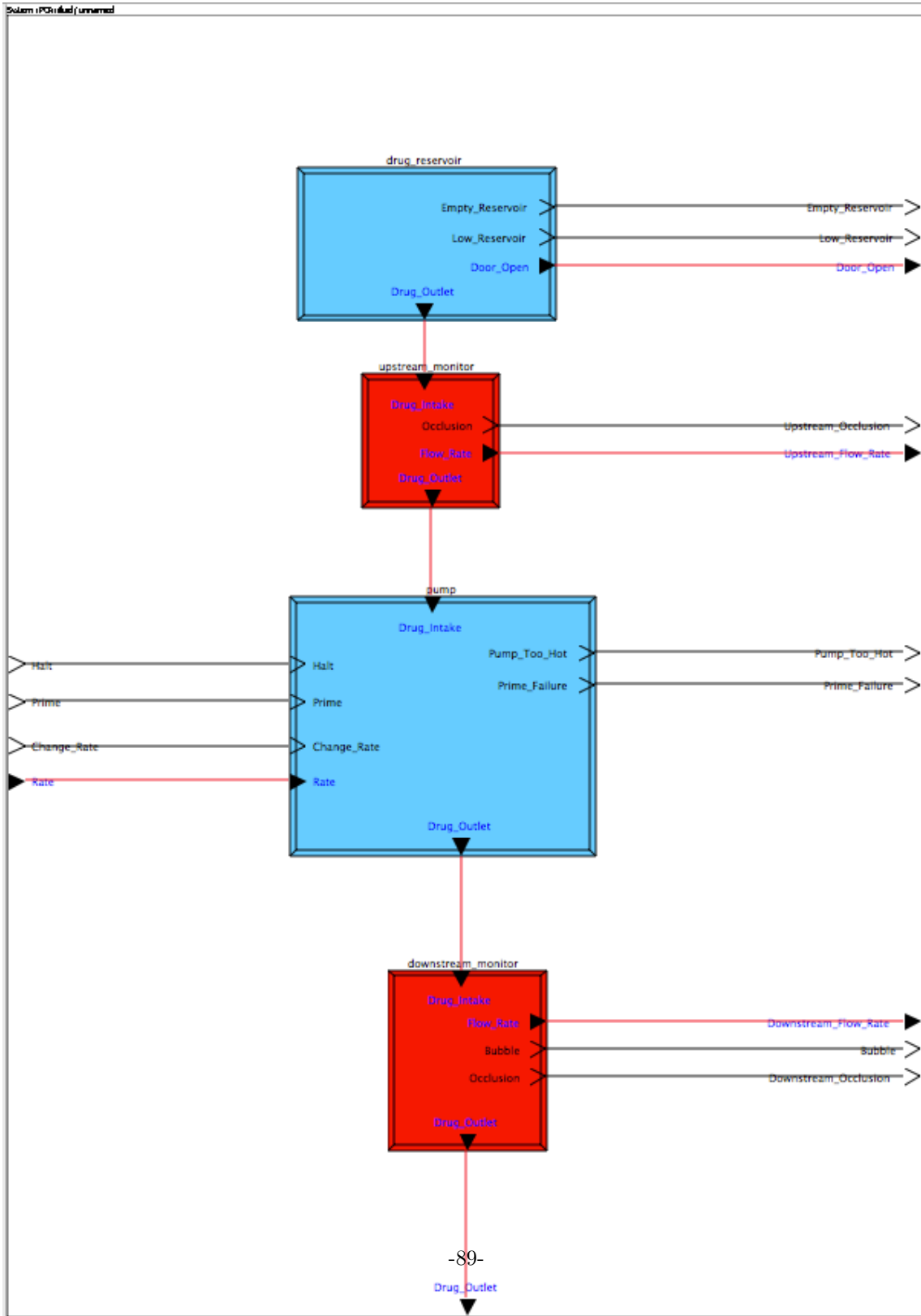

Figure 31: Fluid Subsystem

R5.1.0(2) detect downstream occlusion

R5.1.0(4) detect air-in-line embolism

#### 10.7.4 Drug Reservoir

The *drug reservoir* holds liquid drug until infused.

##### *Allocated Requirements*

R5.8.0(1) drug reservoir

R5.8.0(2) reservoir contents

R5.8.0(3) reservoir tolerance

R5.8.0(9) low-reservoir warning

R5.8.0(10) empty-reservoir alarm

R6.5.0(1) tamper-resistant door

R6.5.0(3) door key

R6.5.0(4) pump case

R6.2.0(8) open door alarm

### 10.8 Safety Subsystem

The *safety subsystem* works with, but is distinct from, the operation subsystem. The safety subsystem detects faults that may harm the patient, signals an alarm or warning, and stop infusion or reduces infusion to a keep vein open rate depending on the fault(s) detected. The components in the safety system are listed in Table 10, and depicted in Figure 32.

Table 10: Safety Components

<b>Component</b>	<b>Behavior</b>
pump_fault_manager	handles pump fault signals
alarm_process	holds thread which controls alarms
fault_logger	record faults
error_detector	handle hardware-detected faults
failure_led	indicates hardware failure

##### *Allocated Requirements*

R6.1.0(1) safety architecture

#### 10.8.1 Failure LED

Hardware faults that prevent execution of thread cause the *failure LED* to illuminate.

##### *Allocated Requirements*

R6.4.0(7) hardware fault indicator

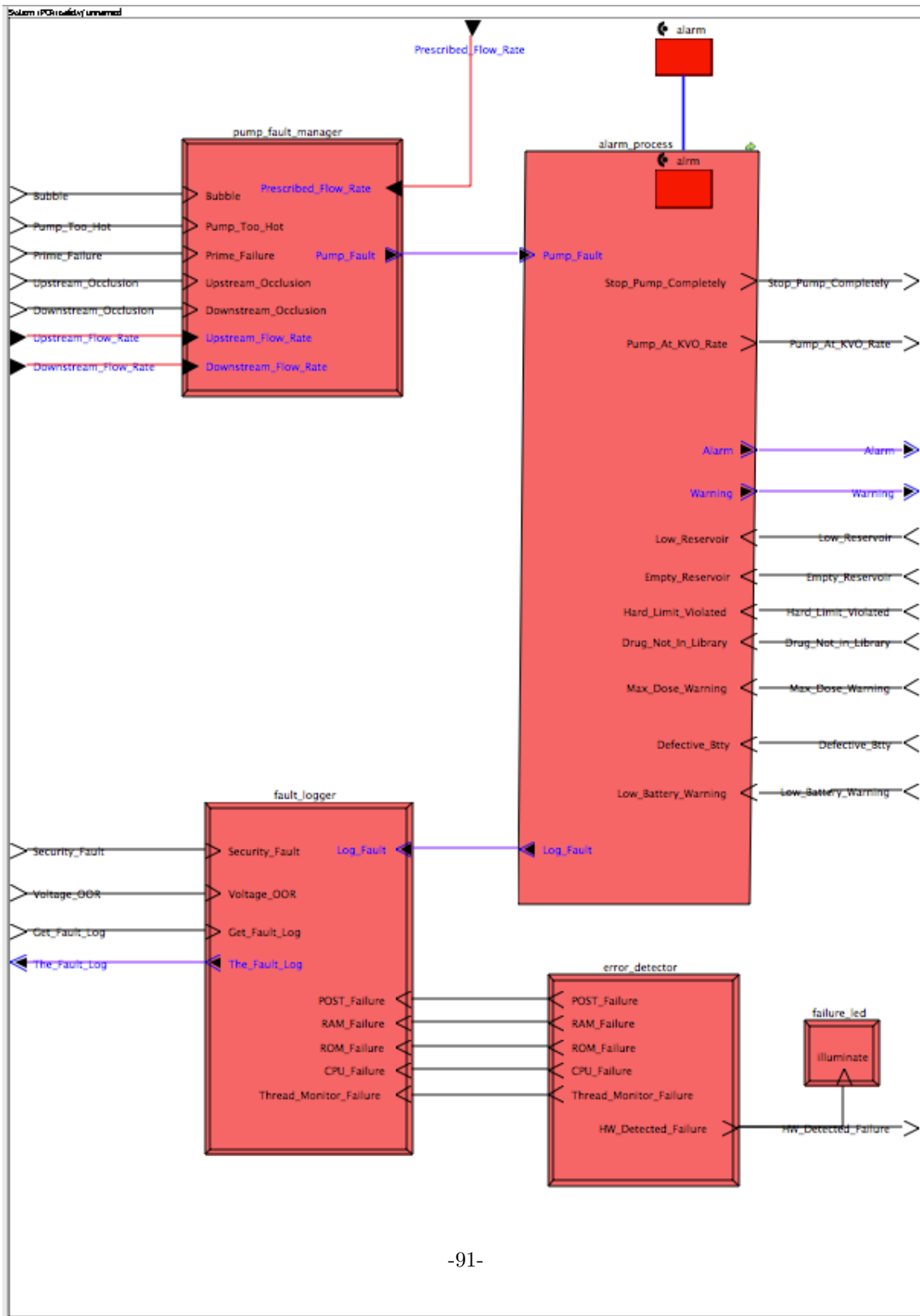

Figure 32: Safety Subsystem

### 10.8.2 Alarm Thread

The *alarm thread* evaluates fault signals to determine whether the infusion rate should be changed, issues alarm and warning signals to be sounded and displayed by the control panel, and creates fault entries to be stored in the fault log.

#### *Allocated Requirements*

- R5.4.0(1) issue alarms and warnings
- R5.4.0(2) basal over-infusion alarm
- R5.4.0(3) basal under-infusion warning
- R5.4.0(4) bolus over-infusion alarm
- R5.4.0(5) bolus under-infusion warning
- R5.4.0(6) square bolus over-infusion alarm
- R5.4.0(7) square bolus under-infusion warning
- R5.4.0(8) pump overheated alarm
- R5.4.1(1) priority
- R5.4.1(2) alarm pump rate
- R5.9.0(5) hard limit
- R5.9.0(6) soft limit
- R6.2.0(3) air-in-line alarm
- R6.2.0(4) upstream occlusion alarm
- R6.2.0(5) downstream occlusion alarm
- R6.2.0(6) occlusion alarm
- R6.2.0(7) empty-reservoir alarm

### 10.8.3 Flow Rate Checker

The *pump fault manager* determines if the measured upstream and downstream flow rates are within tolerance of the specified rate, and aggregates other pump fault indications into a combined pump fault indication.

#### *Allocated Requirements*

- R5.4.0(2) basal over-infusion alarm
- R5.4.0(3) basal under-infusion warning
- R5.4.0(4) bolus over-infusion alarm
- R5.4.0(5) bolus under-infusion warning
- R5.4.0(6) square bolus over-infusion alarm
- R5.4.0(7) square bolus under-infusion warning

### 10.8.4 Error Detector

The *error detector* detects conditions that prevent threads from operating thus could not be detected by the alarm thread.

*Allocated Requirements*

- R6.4.0(1) power-on self-test
- R6.4.0(2) periodic self-tests
- R6.4.0(3) continuous fault-detection
- R6.4.0(4) single-event upsets

**10.8.5 Fault Logger**

The *fault logger* records all errors that are detected. As such it is pure hardware that does not depend on thread execution. It also maintains a hardware *real-time clock* used for timestamps by both event and fault logs, and by ICE messaging.

*Allocated Requirements*

- R5.6.0(2) fault log
- R5.6.0(3) time stamp
- R5.6.0(5) log retention
- R6.4.0(5) masked faults
- R6.4.0(6) hardware detected faults
- R5.6.0(7) fault log size
- R5.6.0(8) real-time clock